

NEW YORK STATE
**SADDLE HORSE
ASSOCIATION**

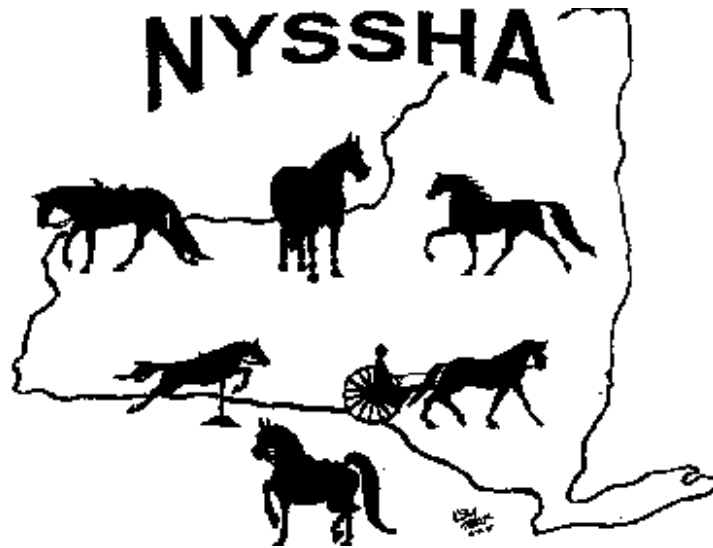

**RULES
AND
REGULATIONS**

REVISED 2018

WWW.NYSSHA.ORG

All exhibitors of NYSSHA pointed competitions are responsible for complete knowledge of and compliance with the rules of competition as set forth in this rule book.

**NEW YORK STATE SADDLE HORSE ASSOCIATION
MEMBER CLUBS 2018**

Adirondack Miniature Horse Club
Montgomery County Equine Club
Sacandaga Saddle Club
Silver Spur Riding Club

To be a member of the **NYSSHA**, exhibitors must belong to one of the member clubs.

If an exhibitor wants to nominate for points but cannot be active in a member club, the following clubs offer social memberships:

Adirondack Miniature Horse Club – Contact: Kelly MacDougall, 211 Smith Rd., Amsterdam, NY 12010 (518) 883-7517

Montgomery County Equine Club– Contact: Deb Yacobucci, 306 Dillenbeck Rd. Palatine Bridge, NY 13428 (518) 852-2920

Sacandaga Saddle Club– Contact: Laura Hayner, 2466 State Highway 30, Mayfield, NY 12117 (518) 848-4858

Silver Spur Riding Club-- Contact: Breanne Riehl, 203 Jackson Vly Rd., Broadalbin, NY 12025 (518) 322-9437

All exhibitors or horses must be nominated to be eligible for year-end awards. In case of transfer of ownership of horse or pony, the point keeper must be notified and accumulated points will be transferred, providing the new owner is a member of the NYSSHA. For equitation and showmanship awards, the exhibitor (rider, driver or handler in the ring) must belong to the NYSSHA. For performance and in hand, the owner must belong to the NYSSHA.

All ties for year end awards will be broken. (2018)

OUR WEBSITE WWW.NYSSHA.ORG

TABLE OF CONTENTS

CONSTITUTION AND BY-LAWS

Article I – Name	5
Article II- Object	5
Article III- Officers	5-6
Article IV- Duties of Officers	6-7
Article V- Elections and Voting	7-8
Article VI- Meetings	8-9
Article VII- Membership	9-10
Article VIII- Dues	10
Article IX- Standing Committees	10-11
Article X- Member Club Horse Shows	11-12
Article XI- Directors	12-13
Article XII- Discipline	13-14
Article XIII- Disbandment	14-15
Article XIV- Amendments	15

COMPLAINTS AND PROTESTS

I. Violations and Penalties	16-17
-----------------------------	-------

GENERAL RULES

I. Age Groups	18
II. Horse Show Entries	18
III. Horse/Pony Definition	18
IV. Age of Horse/Pony	18
V. Miscellaneous Rules	18-21

ATTIRE	22-24
--------	-------

EQUIPMENT/TACK	25-28
----------------	-------

SHOW RULES AND REGULATIONS

I. Year End Awards	29
II. In Hand Division	29-30
III. Fitting and Showmanship	30-36
IV. Western Division	36-46
V. English Division	47-48
VI. Miscellaneous Class Descriptions	49-53
VII. Equitation Divisions	54-57
VIII. Miniature Horse Division	57-59
IX. Liberty Division	60
X. Driving Division	60-65
XI. Hunters and Jumpers Over Fences	65
XII. Hunter Division	65-68
XIII. Hunter Pony Division	68
XIV. Lite Shod Tennessee Walking Horse/Pony Show Rules	68-72
XV. Pony Division	72-75
XVI. Gymkhana Division	76-102
INDEX	103-106

NEW YORK STATE SADDLE HORSE ASSOCIATION INC.

CONSTITUTION AND BY-LAWS

ARTICLE I - NAME

SECTION 1:

The name of this organization shall be NEW YORK STATE SADDLE HORSE ASSOCIATION INC

ARTICLE II – MISSION STATEMENT

SECTION 1:

The mission of this association shall be: to promote a friendly feeling between horse clubs and to cooperate in promoting attendance at member club horse shows and gymkhanas by reasonable distribution of publicity material for member club affairs; to act as a clearing house for show dates; to formulate a set of uniform rules and regulations for games and judging classes to be followed in the conduct and judging of all member club horse shows and gymkhanas.

ARTICLE III – OFFICERS

SECTION 1:

The officers of the association shall consist of a President, Vice-President, Secretary and Treasurer. Said officers shall be elected for a term of one year at the December meeting preceding the Annual Awards Banquet by a majority vote of the clubs present and voting in person. Officers are to be installed at the Annual Awards Meeting.

SECTION 2:

In the event of the death, resignation or permanent disability of an officer before the expiration of his or her term of office a successor who shall hold office until the next annual meeting shall be elected at the first monthly meeting following the officer's death, resignation, etc. If the vacancy is in the office of the President, the successor shall be the Vice-President.

SECTION 3:

In the event of temporary disability of an officer, the association shall elect a member at the first monthly meeting following such disability to act in the place of such officer with all his or her powers while such disability continues.

SECTION 4:

If any officer shall fail to attend three consecutive meetings without a satisfactory reason in the opinion of the membership at the discretion of the association, the office may be declared vacant.

SECTION 5:

At no time shall more than one association officer be from the same member club.

ARTICLE IV - DUTIES OF OFFICERS

SECTION 1: DUTIES OF THE PRESIDENT

A. The President shall be the Chief Executive Officer of the association and shall generally supervise and direct the affairs of the association. He or she shall appoint all special and standing committees. He or she shall be an ex-officio member of such committees and, as such, may participate in the proceedings thereon.

B. The President may be elected for two (2) one (1) year terms. After two years, a President cannot succeed himself or herself in office; neither may any club succeed itself in furnishing a President.

C. The President shall serve as Chairman of Directors' meetings.

SECTION 2: DUTIES OF THE VICE-PRESIDENT

A. The Vice-President shall preside at all meetings of the association and Directors' meetings in the absence of the President. He or she may be elected for two (2) one (1) year terms. After 2 years, a Vice-President cannot succeed himself or herself in office. Neither may any club succeed itself in furnishing a Vice-President.

B. The Vice-President and Secretary shall have a listing of Horse Show Judges with addresses available for members.

C. The Vice-President shall oversee maintaining an association membership list.

SECTION 3: DUTIES OF RECORDING SECRETARY

A. The Secretary of the association shall give notice in writing of all meetings. He or she shall keep the records of the association. In addition to the duties provided by these By-Laws, he or she shall perform such duties as may be assigned to him or her.

B. The Secretary may be elected for three (3) one (1) year terms. After three years, a Secretary cannot succeed himself or herself in office. Neither may any member club succeed itself in furnishing a secretary.

C. He or she shall take the minutes of each meeting, and send a copy to each member club and to association officers.

D. His or her records shall be open for inspection by any member club in good standing at any regular meeting.

E. He or she shall sign all membership certificates and expense vouchers.

F. He or she shall be secretary of all Directors' meetings.

SECTION 4: DUTIES OF CORRESPONDENCE SECRETARY

A. The Correspondence Secretary may be appointed or elected for three (3) one (1) year terms. After three years, a Correspondence Secretary cannot succeed himself or herself in office. Neither may any member club succeed itself in furnishing a Correspondence Secretary.

B. He or she shall work with the secretary in notifying members of meetings and important correspondence.

C. He or she shall, in case of absence of the Recording Secretary, preside as acting Recording Secretary at all association meetings.

D. He or she shall be responsible for the mailing list.

SECTION 5: DUTIES OF TREASURER

A. The Treasurer shall keep the accounts of the association, receive the dues of its member clubs, and report same to the association at the next meeting.

B. The Treasurer shall deposit all funds of the association in a checking account in the name of the association in a recognized bank **within 30 days of receipt** (2018) and shall present an itemized financial report at each regular meeting of the association.

C. The Treasurer shall have general charge of the funds of the association

D. All expenditures of association funds shall be authorized in advance at a regular meeting by AYE or NAY vote of the member clubs, prior to incurring any indebtedness on the part of the association. Invoices for expenditures previously authorized by the association shall be submitted at a regular meeting of the association and, when approved by the association by AYE or NAY vote, the President and Secretary must sign an order drawing on the funds of the association for the same amount which will be the Treasurer's authorization to pay a bill. All checks shall be signed by the Treasurer of the association and countersigned by a duly authorized officer of the association. **Any unforeseen expenses must be approved via phone or email by all NYSSHA officers.** (2018)

E. His or her records shall be open for inspection by any club member in good standing at any regular meeting.

F. Treasurer may be elected for three (3) one (1) year terms. After three (3) years, a Treasurer cannot succeed himself or herself in office. Neither may any club succeed itself in furnishing a Treasurer.

G. He or she shall act as Treasurer of Directors' meetings.

SECTION 6: SPRING FLING and/or FALL ROUND-UP COMMITTEE CHAIRMAN

A. The Fall Round-up Show Committee Chairman shall be elected at the regular monthly meeting in August after the nominees have been presented by the nominating committee. The Show Committee Chairman may succeed himself or herself for three (3) consecutive terms.

B. His or her term of office will commence September 1st and run for 14 months from this date. This will allow two (2) months at the end of the term during which a new chairman will have the opportunity to work with the outgoing officer to become familiar with his or her duties and procedures involved. All final decisions rest with the outgoing chairman.

C. Spring Fling Chairman's term of office will commence May 1st and run for 14 months from this date. This will allow two (2) months at the end of the term during which a new chairman will have the opportunity to work with the outgoing officer to become familiar with his or her duties and procedures involved. All final decisions rest with the outgoing chairman.

ARTICLE V - ELECTIONS AND VOTING

SECTION 1: ANNUAL ELECTION

A. The nominating committee shall meet prior to the October meeting.

B. The nominating committee chairman shall post the slate of officers at the October meeting.

C. Nominations may be made from the floor at the October Meeting

D. The slate of officers shall be submitted to each member club in writing at least thirty days prior to the December Meeting

E. Voting shall take place during the December meeting and shall be voted upon by a closed ballot.

F. Installation of new officers shall take place at the Annual Awards Meeting.

G. Officers shall be elected for a period of one (1) year.

SECTION 2: VOTING

A. The Constitution and By-Laws may be amended at any regular meeting by a two-thirds affirmative vote of all member clubs present by AYE or NAY vote, provided the amendment to be voted upon has been submitted in writing to each member club at least thirty days prior to the date of the meeting.

B. The presence of a majority of member clubs shall constitute a quorum for transacting routine business; however, a two-thirds affirmative vote of all member clubs present, by AYE or NAY vote, shall be required to amend the Constitution and By-Laws, admit a club, expel a club, or adopt rules for gymkhanas and horse shows. All rules for gymkhanas and horse shows, adopted by the association, shall become a part of the Constitution and By-Laws, and cannot be changed or altered from April 30 to November 1 of any year. The vote on admitting or expelling a club shall be by closed ballot.

ARTICLE VI - MEETINGS

SECTION I: ANNUAL MEETING

The annual meeting shall be the Banquet in January. It shall be the duty of the President to call this annual meeting if a place and date has not been decided upon at the previous monthly meeting. Notice in writing shall be sent to the clubs by the Secretary.

SECTION 2: REGULAR MEETINGS

There shall be eight (12) regular monthly meetings (2018) per year, including the annual meeting in January, unless decided otherwise at the previous meeting. The meetings shall be held the last Monday of each month unless otherwise stated. The place of said meeting is to be decided at the previous monthly meeting.

SECTION 3: ORDER OF BUSINESS

- A. Call to order
- B. Roll call
- C. Payment of Dues (must be paid by Annual Meeting)
- D. Reading of minutes of previous meeting for information and/or adoption
- E. Itemized report of Treasurer
- F. Report of Committees
- G. Correspondence and Bills
- H. Unfinished Business
- I. New Business
- J. Announcements
- K. Suggestions for the Good and Welfare of the Association
- L. Adjournment

SECTION 4:

If any occasion arises not covered by the Constitution and by-laws, the Roberts Rules of Order shall govern.

ARTICLE VII – MEMBERSHIP

SECTION 1:

A club wishing to become a member of the association shall supply all information required on a proposed application form supplied by the association and secure the endorsement of a member club of the association. The application shall then be referred to the membership committee, which shall report its findings at the next regular meeting. The applicant club may then be voted on, and a two-thirds affirmative vote of all member clubs present, shall be required to elect membership in the association.

SECTION 2:

To qualify for membership in the association, a horse club must be organized for the purpose of promoting good horsemanship and not for the personal gain of any individual.

SECTION 3:

To qualify for membership in the association, a club must be a bona fide club, which is one in which the activities of the club are controlled by the membership. A bona fide club must consist of at least eight (8) members at all times including the officers of the club.

SECTION 4:

A club desiring membership in the association must attach to its application a copy of its constitution and by-laws together with an affidavit signed by its officers certifying that it is a true and correct copy of same. The applicant club shall also enclose a list of its membership together with addresses. The copy of the constitution and by-laws of the applicant club and the list of members shall remain in the files of the association. A new membership list must be submitted annually, in November and updated in March.

SECTION 5:

Each member club shall be entitled to be represented at the association meetings, but not to exceed seven (7) delegates, including an official spokesman who shall cast the member club's vote. Any member club delegate to an association meeting may speak, make a motion, or second a motion when recognized by the chair.

SECTION 6:

If any club is not represented at two (2) consecutive meetings, the Secretary shall send a letter of inquiry explaining that if they are not represented at the next meeting (3rd absence), the association shall suspend the absentee club from the association and activities therein.

SECTION 7:

Any club failing to abide by the constitution and by-laws of the association may be expelled by two-thirds vote of the member clubs, provided charges have been preferred against it in writing by a member club. Said charges are referred to the grievance committee and the findings of the grievance committee reported to the Association.

ARTICLE VIII DUES

SECTION 1:

The dues of the association shall be \$50.00 per year payable before the annual meeting in January.

SECTION 2:

Assessments other than dues, if any, shall not total more than \$25.00 in any year.

SECTION 3:

All dues and assessments of a member club must be paid in full for the member club to be considered in good standing in order that it be entitled to a vote or a voice in the association meeting.

ARTICLE IX - STANDING COMMITTEES

SECTION 1: AUDITING COMMITTEE

The Auditing Committee shall be composed of three members, each from a different club. It shall be the privilege of the committee to examine the records of the Treasurer at any time; however, this committee shall specifically examine the records at the expiration of the term of any Treasurer in order that they may be approved before being turned over to a new Treasurer.

SECTION 2: GRIEVANCE COMMITTEE

The Grievance Committee shall be composed of one member from each club, chosen by that club. It shall be the duty of the Grievance Committee to receive all complaints and grievances in writing, investigate the same, and report its findings in detail at the next regular meeting of the association. There must be at least two-thirds of the members present at any Grievance Committee meeting. Two-thirds of the people present at a Grievance Committee meeting must agree to any decision of the committee. The decision of the Grievance Committee shall be final. Parties concerned in the grievance are entitled to be present at the Grievance Committee meeting.

SECTION 3: LEGISLATIVE COMMITTEE

The Legislative Committee shall be composed of three members, each from a different club. It shall be the duty of this committee to encourage any state legislation which may be advantageous to the association, to discourage any legislation which may be detrimental to the association, to propose desirable legislation, or make requests from any governmental, state or municipal department which may be advantageous to the association.

SECTION 4: MEMBERSHIP COMMITTEE

The Membership Committee shall be composed of three members, each from a different club. The duties of this committee shall be to investigate each applicant club and report its findings at the next regular meeting of the association.

SECTION 5: SHOW COMMITTEE

The Show Committee shall be composed of one member from each club. It shall be the duty of this committee, in whole or in part, to assist in any way possible the club conducting the horse show or gymkhana and to carry out all rules and regulations adopted for the conduct of member clubs at horse shows and gymkhanas. It shall be the duty of each member club to appoint or elect one person to serve on this committee. It is not expected that every club will be represented on the committee at every horse show or gymkhana conducted by member clubs during the season. The members of the Horse Show Committee present at any horse show or gymkhana shall act for the entire committee.

SECTION 6: CONSTITUTION COMMITTEE

Constitution Committee shall be composed of five members each from a different club. It shall be the duty of this committee to reread and recommend the minutes of the past year's meetings for the incorporation into the Constitution and by-Laws or Rules of this association.

SECTION 7: ANNUAL SPRING FLING and/or FALL ROUND-UP HORSE SHOW COMMITTEE

The New York State Saddle Horse Association will have an annual horse show unless otherwise directed by the association. The horse show chairman will have full authority to select a committee. This committee will meet within 30 days after the association annual horse show for the following purposes:

- 1) To review the previous show and make recommendations (changes) for the following year's association show committee;
- 2) To contract and finalize the hiring of a judge or judges and show grounds; and
- 3) Select show date or dates for the ensuing year. The judge or judges selected by this committee may not judge any other member club's show during the following year.

SECTION 8: HORSE SHOW RULES COMMITTEE

Each club shall appoint delegates to a Rules Committee. The English, Western and Gymkhana divisions shall be equally represented with each club having one vote in each division.

ARTICLE X - MEMBER CLUB HORSE SHOWS

SECTION 1:

Each member club may have up to 4 events (horseshow and/or gymkhana) per year, not necessarily on same weekend. A horseshow and gymkhana sponsored by the same member club and held consecutively on the same weekend will be considered one event. Clubs have option of picking their 1st date before others pick their 2nd. No dates can be changed once flyers published. If more than one club wants an event(s) on same day, the date will be determined by lottery. No other NYSSHA pointed event may be sponsored on the same day.

SECTION 2:

Each member club that has held a point show the previous year shall have first right to claim a corresponding date for their point show to be held in the next succeeding year. If a point show was not held the previous year, first request for any open date will be accepted up to the last Monday in November.

SECTION 3:

Show dates must be in by the November meeting.

SECTION 4:

Club flyers must be turned into the Secretary by the March 1st. Flyers will be reviewed by the Rules Committee prior to publishing. The Rules committee will review flyers to assure that they conform to all rules of the NYSSHA. Each club should have a representative at the review. NYSSHA will have the flyers ready for publishing on May 1. Any changes made to program after May 1 will need to be resubmitted.

SECTION 5:

Member clubs will notify the Association immediately of any cancellation of their shows. This is to be brought up before the body at the next regular meeting for approval. Also, a club must notify everyone on the current mailing list at least ten (10) days prior to their scheduled show date of any cancellation other than by an act of God. Upon failure to do so, said club shall forfeit their membership and fees.

SECTION 6:

A judge may officiate at only one (1) NYSSHA show a year.

Exception: The same judge may judge at subsequent shows those classes that he/she did not officiate at previous show(s) within the same year.

SECTION 7:

No adding of pointed classes to the show program unless it is posted on the NYSSHA website at least 10 days before the show.

ARTICLE XI - DIRECTORS

SECTION 1:

One director shall be named from each club at the annual election of officers. A director may not represent more than one (1) club. WHEREAS, the New York State Saddle Horse Association being desirous of forming a Membership Corporation resolves that the Constitution and By-Laws be amended to provide for a director for each member group or club making up said association and that it further be RESOLVED, that each directorship correspond in time with the election of present officers, and let it further be RESOLVED, that the duties of said directors consist of being a Nominating Committee and part of the Executive Committee and aid in determining association policy. Any action taken by this body will be subject to approval by the Association as prescribed in the Constitution and By-Laws, and let it further be RESOLVED, that all meetings of said body will be called only after at least ten (10) days notice of such, if said notice is to be mailed; or five (5) days notice of such if said notice is given by personal contact,

telephone, or etc. and let it be further be RESOLVED, that a Directors' meeting be held annually or as needed.

ARTICLE XII – DISCIPLINE

SECTION 1:

Any NYSSHA member or officer whose behavior is “tending to injure the good name of the organization, disturb its well-being, or hamper it in its work” is subject to disciplinary action.

SECTION 2: REQUEST FOR DISCIPLINARY ACTION

Any requests for disciplinary action as described in section 1 must be submitted in writing to an officer of the association and include a thorough description of the alleged infraction (s) and must be accompanied by a \$50.00 deposit, which will be returned when and if the disciplinary committee finds there is sufficient evidence to initiate an investigation and a trial.

NYSSHA as an organization, may request a disciplinary action by submitting a written request to an officer as described in section 1 which must be supported by 3 members of the disciplinary committee. No fee will be required for this request.

SECTION 3: DISCIPLINARY COMMITTEE

This is an empowered committee and shall consist of the director from each member club.

SECTION 4: PROCEDURES

- A. Once a request for disciplinary action has been received by an officer of NYSSHA, a meeting of the disciplinary committee will be held within 30 days.
- B. Once the disciplinary committee meets and finds the request is valid, it will appoint an investigative and a trial committee. The members of this committee should be chosen for their integrity and good judgment. The committee should quietly conduct its investigation and make a sincere effort to get the facts. Any information collected is confidential. The committee should also talk with the accused to hear his or her side of the story.

SECTION 5: HOLDING A TRIAL

Because a trial is a serious event for any organization and should rarely be used, there are specific procedures to follow to protect the rights of the accused:

A trial is held in executive session.

- The accused has a right to due process - to be notified of the charges, given time to prepare a defense, and allowed the right to appear and defend himself or herself.
- The trial committee should have different members than the investigating committee.

If the members decide to have a trial, the secretary immediately sends by registered mail a letter notifying the accused of the time, date, and place of the trial, as well as the charges against him or her. (The letter should include a copy of the exact charges.) At the trial, the secretary should have on-hand a copy of the letter that was sent to the accused and a signed return receipt to prove that he or she received the letter.

The trial is a hearing. Members of the organization appointed to present the evidence against the accused are called managers. They should not be thought of as prosecuting attorneys; their intent should be to get at the truth and see that the outcome is just. The accused has a right to be represented by counsel and to speak and present witnesses in his or her own defense. The defense counsel may be an attorney but must be a member of the organization, unless the organization agrees by a vote to allow a nonmember to represent the accused.

At the beginning of the trial, the charges are read and the accused is asked how he or she pleads. If the accused answers "guilty," there is no reason to proceed with the trial. If he or she pleads not guilty, the members proceed with opening statements by the managers and then by the accused. Next, witnesses are presented by the managers and then by the accused. Rebuttal of witnesses by the managers and then by the accused is followed by closing arguments on both sides.

After closing arguments, the accused leaves the room and the assembly discusses and takes a vote. Each charge is read, debated, and voted on. If the accused is found guilty, the next business in order is determining the penalty. Usually the managers propose the penalty, and the members can debate and amend that motion. One member can demand that the vote be taken by ballot. Removing the person on trial from membership requires a two-thirds vote. After the penalty is decided, the accused is brought back into the assembly and told the results.

A trial is an extreme measure. The best policy is to talk to the member and see what can be resolved before the situation ever reaches this proceeding.

SECTION 6: PENALTIES

- A motion that the member must apologize.
- A motion to censure the member.
- A motion to suspend the member's rights for a designated period of time.
- A motion to expel the member from the organization.

If the assembly wants the member to leave the hall while they discuss the penalty, someone must present this option in the form of a motion, which takes a majority to adopt. If the assembly does not ask the member to leave during the discussion, it should allow that person to speak briefly in his or her defense. If the member denies the charges, the secretary can read back what he or she has said or done. Any penalty other than expulsion requires a majority vote to adopt; expulsion takes a two thirds vote. At the request of a single member, the vote on a penalty motion must be taken by ballot.

ARTICLE XIII - DISBANDMENT

SECTION 1:

In case of dissolution of the New York State Saddle Horse Association, being voted on at a regular or special meeting, provided thirty(30) days written notification is given, two-thirds of the member clubs in good standing, represented in person, all property shall be converted to cash and the total cash reserve, after any and all debts against the Association are satisfied and shall be given in the name of the Association to a college research, or charitable foundation for the *betterment* of the horse (horses).

ARTICLE XIV – AMENDMENTS

SECTION 1:

A proposed amendment must be signed by two member clubs in addition to one proposing the amendment before it can be submitted to an association meeting for consideration.

COMPLAINTS AND PROTESTS

All complaints or protests must be in writing and drafted to include all points or phases which the aggrieved desires to cover and which s/he believes s/he can confirm or verify. E-mails will not be accepted. Exact details regarding any alleged violation of the rules are essential for the indictment. Said protest must be in writing, signed and addressed to the Secretary of the Association and must be accompanied by a deposit of \$25.00, which will be returned, when and if at the hearing the grievance committee finds the charges factual and sound. Any complaint must be filed and postmarked within five (5) business days of the occurrence of the alleged violation. Address of secretary to be on WWW.NYSSHA.ORG.

I. VIOLATIONS AND PENALTIES

The provisions of this rule shall apply in connection with any NYSSHA Show to the following persons: owner, exhibitor, agent, trainer, manager, rider, driver, show official, show employee, or member of the family of the above, individual member or any person who acts in a manner in violation of the rules of the NYSSHA or deemed prejudicial to its best interests.

A. **Violations:** A violation is any act prejudicial to the best interests of NYSSHA, including but not limited to the following:

1. Violation of the rules of NYSSHA.
2. Acting or inciting or permitting any other to act in a manner contrary to the rules of NYSSHA, or in a manner deemed improper, unethical, dishonest, unsportsmanlike or intemperate, or prejudicial to the best interests of NYSSHA.
3. Any act committed or remark made in connection with the show considered offensive and/or made with the intent to influence or cast aspersions on the character or integrity of the judging; approaching a judge before or after a decision without first obtaining permission from the Show Committee or Steward; inspecting a Judge's card without the Judge's permission.
4. Failure of an exhibitor or his/her representative to sign the entry blank of a show in which he competes, or the Statement of Intent Not to Sue if available.
5. Physical assault upon a person and/or cruelty to a horse.
6. Failure to obey any penalty imposed by the NYSSHA.
7. Exhibiting any horse while in the care, training, or custody of a suspended trainer or owner
8. Riding, exhibiting, coaching, or training for the benefit, credit, reputation, or satisfaction of a suspended person.
9. Falsely representing the age, name or show record of a horse or pony.
10. Falsely representing the age or show record of a rider or exhibitor.

B. **Penalties:** If found guilty, the accused shall be subject to such penalty as the Grievance Committee may affirm, including but not limited to:

1. **CENSURE:** A vote of Censure shall be listed under the defendant's name in the Secretary's Record of Penalties. If the defendant is found guilty of a further violation the defendant shall be subject to a heavier penalty than for a first offense.

2. SUSPENSION of such persons for any period from showing or having others show, exhibit or train for him/her. A suspended person is forbidden for the time specified in the sentence to hold or exercise office in NYSSHA or in any NYSSHA show, from the privilege of taking any part whatsoever in any NYSSHA show, and is excluded from all show grounds during NYSSHA shows, as an exhibitor, participant or spectator.

3. SUSPENSION for any period of the horse or horses, completely or in part owned, leased or of the stable of such person at the time of the alleged violation. The Grievance Committee may at a later date remove the suspension of said horse or horses if a sale thereof is made in such manner as to be a bona fide transaction and not with the intention of relieving the suspended owner of penalty.

4. SUSPENSION for any period of any volunteer or any employed person who rides or exhibits for the benefit, credit, reputation or satisfaction of the person disciplined.

5. EXPULSION from all NYSSHA Shows.

6. FORFEITURE of trophies, ribbons, and prize money won in connection with the offense committed.

7. FINE

C. Notification of Penalty:

1. The Secretary of NYSSHA shall notify the management of every NYSSHA show of the penalizing of any person and of the period thereof. Any NYSSHA show which allows a suspended or expelled person to participate is itself liable to suspension or expulsion.

2. When a grievance is placed against a member club, that club shall post a bond for the amount of money that the grievance is for.

3. Any person or persons filing or one against whom a protest or charge is filed, shall be entitled to a hearing. This hearing to take place before the Grievance Committee at a date and place designated by them not later than 30 days after the protest has been received by the secretary. The secretary shall immediately notify the Chairman of the Grievance Committee, who shall in turn, notify all interested parties at least five (5) days in advance, by written notice of the time and place for the hearing. (See additional information in previous rule)

GENERAL RULES

I. AGE GROUPS

Age of exhibitors shall be determined as of January 1st of each year. No other age groups will be pointed in equitation or horsemanship classes. If there is a lack of entries in either of the junior equitation classes, (13 and under) and (14 – 17), the classes may be combined into a 17-year-old and under equitation class. Points will be given to riders in their appropriate age groups. The age group rule is to be waived in the case of Huntseat Equitation Over Fences.

A. Equitation and Horsemanship

1. 3 – 8 Leadline
2. 11 years old and under- Walk Trot or Jog (Alternate Gait)
3. 13 years old and under
4. 14 – 17 years old
5. 18 years old and over
6. Jack Benny – 39 years old and over

II. HORSE SHOW ENTRIES

A. Each entry shall have:

1. One number for each horse/rider combination.

Horse show numbers must be worn on the back of exhibitors or on both sides of the horses while in the ring. Failure to display correct entry number on Horse or Exhibitor is reason for disqualification.

B. All shows are to use entry sheets and judges' cards.

III. HORSE/PONY DEFINITION

- A. Horse Division:** No animals over 14.2 may enter pony classes. No animals under 13.2 may show as a horse. All show committees reserve the right to measure animals during any class. USEF Pony cards specifying 14.2 hands and under will be accepted as proof.
- B. Pony Division:** A pony shall be designated at 14.2 hands and under. Pony classes shall be governed by the same class rules as for horses.
- C. Horses and Ponies can show together, except for pleasure and country pleasure driving classes (Refer to pages 60 and 64).**
- D. Height of Horse/Pony:** Exhibitors are responsible to know the height of their horse/pony and any horse/pony of questionable height is subject to measurement. Equines to be measured appropriate to breed and standing square.

IV. AGE OF HORSE/PONY

For competition purposes any horse/pony is considered to be one year old on the first day of January following the actual date of foaling and its birthday shall be the first day of January each year following.

V. MISCELLANEOUS RULES

A. No Stallions will be allowed in children's or junior classes. All stallions and all horses that tend to kick should wear a red ribbon in their tails.

B. All horses/ponies shall be show sound. Any horse/pony showing evidence of lameness or broken wind shall be refused an award. The judge has the authority to dismiss from a class any horse/pony that is unsound. Obvious lameness will be cause for disqualification. There shall be no rule barring any horse from any class for which said horse may qualify.

C. If stop watches are used; there shall be two timers per horse in all timed events. Electric timers may be used instead of stop watches.

D. There shall be open competition in any class whether or not the riders are members of a member club of the NYSSHA.

E. For Junior Classes – No more than 10 horses may canter or lope at one time.

F. Any saddle class having more than 20 horses in it must be split and worked in 2 sections and the top horses in each section are to be reworked for pinning. Driving classes should be split at the discretion of the show committee.

G. A horse must be at least 2 years old to show under saddle.

H. A horse must be at least 2 years old to show in a driving class.

I. In classes with inexperienced horses/ponies (for example beginner, maiden, novice, green) limit the number of horses in the ring at one time. Classes must be split if over 15.

J. Classes may enter the ring AT A WALK after the class before them is in the lineup. The following classes are exceptions, and next class entries may not enter the ring until the ring is clear: Fitting & Showmanship, Leadline, W/T/J/AG 11 & under, Saddle seat classes, Driving classes, Beginner Rider classes, Green Horse classes.

K. Failure to follow course or pattern will be an automatic disqualification from said class or event.

L. Schooling over any type of course will not be permitted unless specified by the show committee. Exhibitors violating this rule will be disqualified.

M. Judges must adhere strictly to NYSSHA rules.

N. Judges may use their own discretion for additional performance from exhibitors.

O. It shall be the duty of the host club to see that their show is conducted according to the NYSSHA rules. Any situation not covered by NYSSHA rules will be governed by USEF rules.

P. It is suggested that all NYSSHA shows have this statement on their flyers: “All dogs must be leashed and restrained. If a dog is found to be unleashed, the owner and the dog may be asked to leave the show grounds. For safety purposes, it is strongly suggested that no dogs be near or around the show ring, entrance and exit gate(s). If a dog is found to be disturbing or dangerous the owner will be asked to remove the dog from the show grounds immediately. No entry fees will be refunded.”

Q. All NYSSHA shows are to put the class specifications (including gaits) on the judge’s cards.

R. Tack changes between classes will be given three (3) minutes and must be done outside of the ring gate.

S. Hoof boots that cover entire sole of hoof are allowed in riding classes. Bell boots allowed in Gymkhana classes only.

T. Member clubs may have any class or event they want in their shows or gymkhanas. It is strongly suggested that show committees maintain the classes listed on their show flyer as much as possible. Any class or event not covered by NYSSHA rules or USEF rules shall be judged as designated by the host club and the rules governing such an event or class shall be printed on the prize list or entry sheet covering the show, or posted at the show. Copies of these rules must be submitted to the judge(s) engaged for the show.

U. There shall be a standard judge's card used for each association club show. The judge's card, together with the list of entrants, (entry sheet or class sheet) shall be submitted to the Association Secretary or Point Keeper within twenty-one (21) days from the date of the show. Failure to comply will make the club liable to a penalty of **\$50.00**, payable to the Treasurer of the Association.

V. There shall be a Ringmaster and/or Ring Secretary, an appointed Judge or Judges and Announcers for the shows conducted by member clubs.

W. Changes of gaits, results of classes or events, time for races and awarding of prizes shall be announced.

X. In the case of an emergency, the host club may appoint three (3) members from three (3) different clubs, to act as judges for the show. An emergency means failure of the judge or judges to appear at the show. The show committee must produce correspondence of the parts or parties involved. Also, willfully disregarding the rules set down by the NYSSHA by the judge or judges constitute an emergency.

Y. The show committee or judge may and shall immediately order out of the ring or off the grounds: any person not showing sportsmanship, any person using profane language, any person displaying unsafe behavior and/or any unruly horse, habitual kicker, striker, biter or a horse not under control.

Z. The judge may only be addressed through the show committee.

AA. Any exhibitor or member of his/her family who harasses or is abusive to the judge during or between classes about the judging, shall be barred from showing for the balance of the year and NYSSHA members will lose all points received up to and including that date. It will be that show committee's duty to notify the Secretary of NYSSHA in writing within 48 hours and the secretary will in turn notify the offending parties in writing within 48 hours of his/her notification of the action being taken against them. This party will also be informed that they have the right to file a grievance to reverse the decision. If a grievance is filed, the decision will be delayed until the Grievance Committee has met and made a decision. The decision of the Grievance Committee will be final. It will be up to NYSSHA to rule on this grievance as quickly as possible. The Association Secretary will also notify each of the member clubs of the action being taken.

BB. Cruelty to, or abuse of a horse by any person at a recognized show is forbidden. The judge and/or show management has the authority to dismiss from the class or show grounds, any person for cruelty to, or abuse of a horse. If a rider is disqualified from showing by the management, or by officials, or if a horse is entered and not shown, the entry fee will not be refunded. Evidence of bleeding, either from the mouth or other areas of the horse shall be cause for elimination of that horse from that class. Showing a horse with raw or bleeding sores around the coronet, pasterns or legs is prohibited.

CC. When a check is returned to a club for insufficient funds, or an exhibitor has unpaid show balances or expenses, the following shall be the procedure: the exhibitor must reimburse the club or association for all funds and/or expenses incurred within 15 days of the initial occurrence. Failure to do so will result in exhibitor's name being reported to NYSSHA for appropriate action. The exhibitor will not be allowed to attend or participate in any member club or Association function until all fines and debts have been settled with owed club or Association.

DD. The Intent Not to Sue Form must be on all Show flyers.

EE. Per NYS V&T Law No. 1265 all riders 17 years of age and under must wear a helmet meeting or exceeding ASTM F1163 (Safety Equipment Institute Certified) Equestrian Standard.

FF. Exhibitors must be prepared to show proof of age for Junior Horses, Registration Certificates for registered horses and Coggins for unregistered horses.

GG. In accordance with NYS laws, current Coggins are required to be presented for all horses at a NYSSHA show. Proof of current rabies vaccination is also required for all horses at a NYSSHA show. Equines under 6 months of age are exempt. Out of state horses must comply with NYS laws. Laws can be obtained at www.agriculture.ny.gov.

HH. Being a member of the show committee does not exclude an individual from showing at said show.

ATTIRE

Protective headgear meeting or exceeding ASTM/SEI F1163 Equestrian Standard is mandatory for all exhibitors under 18 years of age per NYS V&T Law.

ACADEMY CLASSES:

Leadline: Riders to wear black jodhpur pants or black pants, jodhpur boots or shoes with a heel, long sleeved, buttoned down shirt with a tie. Vests sweaters or gloves are optional.

Hunt seat: Riders to wear jodhpurs, breeches or black pants, jodhpur, paddock, hunt boots or shoes with a heel, long sleeved, buttoned down shirt with tie or choker. Academy Hunt seat riders may not wear riding jackets.

Saddle seat: Riders to wear black or navy blue jodhpur pants or black pants, jodhpur boots or shoes with a heel, and long sleeved, buttoned down shirt with straight tie. Vests, sweaters and gloves are optional. No jackets or hats are allowed

Western/Stockseat: Riders to wear well-fitting long black pants, boots or shoes with a heel, long sleeved, buttoned down shirt and tie. Vest or sweaters are optional. Academy stock seat riders must not wear chaps.

DRIVING CLASSES:

Exhibitor's attire to be neat and appropriate to vehicle shown. Bare shoulders are not appropriate.

EQUITATION CLASSES (includes Green Horse; Beginner Rider; Five and Under;

Walk/Trot/Jog/Alternate Gait; and all other classes that allow multiple seat entries)

Hunt seat: Riders to wear appropriate conservative huntseat jacket or coat, breeches (or jodhpurs), appropriate shirt, tie, choker, pin and boots. Conservative dark hunting cap, derby or protective headgear is mandatory. Spurs of the unrowelled type, crops or bats optional.

Saddle seat: Attire for all saddle seat classes includes informal attire, formal attire (optional) if time designated, and day coats of any color. Kentucky jodhpurs, jodhpur boots, and a derby or soft hat are required. Exhibitors may also use protective headgear and/or gloves. Informal attire may be worn in all saddle seat equitation classes. Informal: Conservative colors are preferred for saddlesuits (i.e. herringbone, pin stripes and other combinations of colors that appear to be solid). Solid colors include black, blue, gray, dark burgundy, dark green, beige or brown jacket with matching jodhpurs, derby or soft hat or protective headgear and jodhpur boots. Day coats are acceptable in all classes. Formal attire may be worn after 6:00 p.m. or during evening sessions but is not mandatory. Formal: Even more conservatism is required for evening wear. Solid colors include dark gray, dark brown, dark blue or black tuxedo-type jacket with collars and lapels of the same color, top hat, jodhpurs to match and gloves, or dark colored riding habit, accessories and jodhpur boots. Contrasting jackets may be worn.

Western/Stockseat: Boots, appropriate western style clothing and a western hat or protective headgear are mandatory. Long sleeve shirts must be worn in all Western classes. Chaps are optional.

FITTING AND SHOWMANSHIP:

Each exhibitor should present a clean and neat appearance attired in appropriate appointments consistent with the type of horse or pony shown (refer to equitation class section above). Miniature Horse exhibitors are to be dressed in neat, clean clothing. Suitable gloves are encouraged. Suitable hat and footwear is required. Western horses and ponies must be shown in a halter, English horses or ponies may be shown in either a bridle or halter. Leadliners must show in a halter regardless of seat. The bridle must correspond to the type of animal shown and the attire of the exhibitor.

GYMKHANA CLASSES:

Protective headgear is required for all leadline participants.

Boots, a long or **short sleeve**, western style button up shirt and western pants are mandatory in all classes. No tank tops. Western hats or protective headgear is required. Protective headgear is encouraged for all but mandatory for exhibitors under 18 years of age. No ball caps.

IN HAND and LIBERTY CLASSES:

Exhibitors in the In-Hand and Liberty classes may show in attire appropriate to the seat shown. Hats are optional, however if worn must be appropriate to the seat shown. No baseball hats. Other acceptable attire is clean conservative clothing such as polo shirts with no logos or dress shirts, jodhpurs or dress pants (no blue jeans unless wearing western attire and then belts are to be worn). No T-shirts. In western classes, long sleeve shirts must be worn. Exhibitor must wear appropriate safe shoes.

LEADLINE CLASSES:

Protective headgear is required for all leadline participants.

English/Hunt seat: Riders should wear appropriate conservative huntseat jacket or coat, breeches (or jodhpurs), appropriate shirt, tie, choker, pin and boots.

Saddle seat: Riders may wear either informal attire, formal attire (optional) if time designated, or day coats of any color. (refer to equitation section above for full descriptions).

Western/Stockseat: Riders to wear boots, and appropriate western style clothing. Long sleeve shirts must be worn. Chaps are optional.

Leadline handlers: Handlers must be attired appropriately for entry into the show arena. Hats are optional, however, if worn, must be show appropriate. No baseball caps. Other acceptable attire is clean, conservative clothing such as polo shirts with no logos; long or short sleeve dress or western-style collared shirts; jodhpurs, breeches, dress pants or belted jeans. No tee shirts or tank tops. Leadline handlers must wear safe, appropriate shoes or boots. No sandals, sneakers or bare toed shoes.

LITE SHOD:

Hunt seat: Riders to wear appropriate conservative huntseat jacket or coat, breeches (or jodhpurs), appropriate shirt, tie, choker, pin and boots. Conservative dark hunting cap, derby or protective headgear is mandatory. Spurs of the unrowelled type, crops or bats optional.

Saddle seat: Attire for all saddle seat classes includes informal attire, formal attire (optional) if time designated, and day coats of any color. (refer to equitation section above for full descriptions).

Western/Stockseat: Boots, appropriate western style clothing and a western hat or protective headgear are mandatory. Long sleeve shirts must be worn in all Western classes. Chaps are optional.

MINIATURE HORSE and PONY 11.2 AND UNDER JUMPERS:

Exhibitor's type of footwear **may** include any athletic type shoe.

EQUIPMENT/TACK

General Rules:

Protective headgear meeting or exceeding ASTM/SEI F1163 Equestrian Standard is mandatory for all exhibitors under 18 years of age per NYS V&T Law.

Tack changes between classes will be given 3 minutes and must be done outside of the ring gate.

Hoof boots that cover entire sole of hoof are allowed in riding classes. Bell boots are allowed in Gymkhana classes only.

All stallions and all horses that tend to kick should wear a red ribbon in their tails.

ACADEMY CLASSES:

In Academy Classes schooling tack may be used.

Fitting and Showmanship and Leadline: Horses/ponies to be shown in a halter. Hunt seat: Any standard English bit and standard curb chains may be used. Martingales are allowed. An appropriate English saddle is required, preferably of the Hunt seat type.

Saddle seat: Horses/ponies may be shown in a snaffle bridle with martingale or a Pelham/full bridle. Flat cut back English saddles are to be used. Western/Stockseat: Any standard Western or snaffle bit may be used. An appropriate Western saddle is required

DRIVING CLASSES:

Snaffle bits or other types of traditional driving bits are required in all driving classes. Bits may be covered with leather or rubber. Side checks or over checks are permitted, but not required. Running martingales are acceptable on all snaffle bridles. (Standing martingales are only acceptable for Stanhope Gig and George IV Phaeton.) Boots or bandages of any kind are prohibited except at the discretion of the show committee. The use of a kicking strap is prohibited in all driving classes. Cavessons are required in all driving classes

EQUITATION CLASSES (includes Green Horse; Beginner Rider; Five and Under; Walk/Trot/Jog/Alternate Gait; and all other classes that allow multiple seat entries)

Bosal: Rawhide braided or leather braided Spanish type hackamore of the regularly accepted plain type. No mechanical hackamores are permitted. Two hands on the reins are permissible.

Five and Under: Snaffle bits and bosals are permitted.

English Division (Hunt Seat and Saddle seat): All classes in the English division require appropriate English saddles. A standard English bit with or without standard curb chains must be used. Spurs of the unrowelled type, bats, crops and whips optional. Martingales are not permitted in the English Division, other than in over fence classes or driving classes.

3 Gaited Trimmed and Untrimmed and Saddle seat. Appropriate English saddle, Weymouth or Pelham bridle, no martingale.

Western/Stockseat: Spurs are optional in all western classes, but they cannot be used forward of the cinch. Any standard western bit may be used. Chain curbs are permissible, but must meet the approval of the judge. Must be at least 1/2 inch in width and lie flat against the jaw of the horse. No wire curbs, regardless of how padded or covered; no chinstrap narrower than 1/2 inch; no nosebands and no tie downs permitted. Any bit with a shank must be ridden with one hand regardless of the mouthpiece. (i.e. Jointed or solid.) Snaffle bits and bosals are acceptable for any junior horse (Five and Under) ridden Western. Snaffle bits and bosals are acceptable for any age horse being ridden Western in the Green Horse division. References to a snaffle bit in western classes means the conventional O-ring, egg-butt or D-ring with a ring no smaller than 2" (5.08 cm) and no larger than 4" (10.16 cm). The inside circumference of the ring must be free of rein, curb or headstall attachments which would provide leverage.

Examples of Snaffle bits

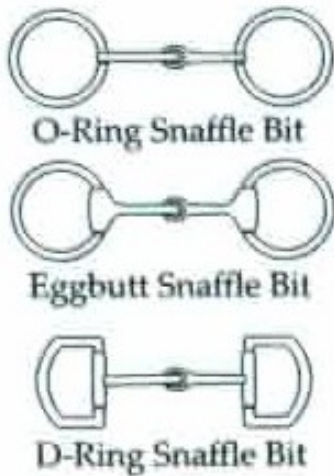

Except for Five and Under horses/ponies and Green horses/ponies being ridden in a snaffle or bosal, and in Bosal Pleasure classes with any age horse, only one hand may be used for reining, and the hand must not be changed. The hand is to be around the reins; one finger only between split reins is permitted. When using a romal, the extension may be carried in the free hand with a 16-inch spacing between the reining and the free hand holding the romal. In trail classes, it is permissible to change hands to work an obstacle. When exhibiting a junior horse (Five and under) and Green Horse in a snaffle or bosal or exhibiting in Bosal Pleasure, two hands must be used on the reins. When exhibiting a western horse in a snaffle the reins must be crossed over the horse's withers.

FITTING AND SHOWMANSHIP:

Western horses and ponies must be shown in a halter, English horses or ponies may be shown in either a bridle or halter. The bridle must correspond to the type of animal shown and the attire of the exhibitor. Leadliners must show in a halter regardless of seat. Tack should be clean, neat and appropriate

GYMKHANA CLASSES:

An English or Western saddle must be used. The saddle must correspond to the bridle. Any standard English or Western bit, hackamore or noseband may be used. The method of holding the reins is optional. Spurs of any standard type without sharp points may be worn; rowels shall not be wired or taped. Spurs are to be used behind the cinch only. They are to be used with discretion and anyone abusing their use shall be disqualified. Tie downs will be permitted in gymkhana events for control. Bats or crops are permissible, but may not be used forward of the cinch. Bats or crops must be used with discretion. Only flat leather bats are allowed.

Leadline: Protective headgear is required for all leadline participants. Halter & Bridle Is Required. Lead must be attached to halter. Over the horn stirrups may be used in leadline classes.

HUNTER DIVISION (HORSES/PONIES)

Regulation snaffles, pelhams and full bridles, all with cavesson nose bands, are recommended and a judge at his own discretion may penalize a horse with non-conventional types of bits or nosebands. In hack, under saddle and tie-breaking classes, martingales of any type are prohibited. Boots and bandages are prohibited, except in the case of inclement weather when show committee may permit their use.

LEADLINE CLASSES:

Protective headgear is required for all leadline participants.

Halter and Bridle Is Required. Lead must be attached to halter. Over the horn stirrups may be used in leadline classes.

LIBERTY

Whips and shaker bottles are allowed.

LITE SHOD:

English: Bridles should be of the type commonly used by walking horses with a single pair of reins. Any standard walking horse/pony or English bit, including snaffles, are acceptable. Bits with shanks over 8 inches are prohibited. Gag bits are prohibited. Shanks are measured from the top of the metal to the very bottom of the metal. The rings are not included in the measurement. Curb chains or straps must be at least 1/2-inch-wide and must be flat against the jaw. Saddles should be of the flat English type. Cut backs, Plantation, Australian Stock Saddles, Dressage and Side Saddles are acceptable. Breast straps are optional. Braids should be neatly attached at the forelock and mane

Western: Bridles must be a standard Western bridle with no cavesson. The bit must be a standard Western bit with shanks not to exceed 8 inches. Gag bits are prohibited. Shanks are measured from the top of the metal to the very bottom of the metal. The rings are not in-

cluded in the measurement. Curb chains or straps must be at least 1/2-inch-wide and must be flat against the jaw. Mechanical hackamores, draw reins, tie downs, running or other type martingales, cavesson nosebands, crops, bats and whips are prohibited. Bosals or ordinary ring snaffles may be used on five-year-old or younger Western pleasure horses/pony only. When using a bosal or ring snaffle the rider may use two hands on the reins. When exhibiting a junior horse/pony in a snaffle the reins must be crossed over the horse's withers. Saddles must be a Western Saddle. Breast straps are optional. Braids are prohibited in all Western classes (including in hand and Model) when the horse/pony is shown in a Western bridle or show halter.

In Hand: Bridle or show halter allowed.

Pleasure; 2-Gait and 3-Gait:

Appropriate English or Western tack are permitted.

MINIATURE HORSE and PONY 11.2 and Under

Jumpers: Whips are permitted. Front leg wraps and/or boots are optional.

Obstacle in Hand: Horse/Pony to be shown in a halter with lead. Whips or crops are prohibited. Tying up of long tails is permissible.

Obstacle Ground Driving: Horse/Pony to be shown in appropriate driving or open/closed driving bridle with check and surcingle. Any additional harness parts must be securely tied up. Driving line of a safe and appropriate length to be used, run through surcingle ring turrets and no other parts of the harness including tugs or shaft loops. Driver must carry a suitable driving whip.

SHOW RULES AND REGULATIONS

I. YEAR END AWARDS

A. General Rules

1. Awards are only for NYSSHA Members and their children.
2. All performance classes to be pointed must be open and/or have comparable age groups for all classes.
3. Games in Horse Shows will count as Gymkhana points.
4. Points for Knock Down and Out class, at point gymkhanas will count toward the Gymkhana award and not toward the Hunter Over Fences award.
5. Points will be awarded as follows (no point for entering the class): 6 points for first, 5 points for second, 4 points for third, 3 points for fourth, 2 points for fifth, 1 point for sixth in all classes with at least 6 entries. Classes with less than six entries to be pointed as follows.

No. of entries	Placings	1st	2nd	3rd	4th	5th	6th
1		1					
2		2	1				
3		3	2	1			
4		4	3	2	1		
5		5	4	3	2	1	
6		6	5	4	3	2	1

6. All exhibitors or horses/ponies/minis must be nominated to be eligible for year-end awards. Points are accumulated from date of nomination. In the case of transfer of ownership of horse/pony/mini between Association members, the point keeper must be notified and accumulated points will be transferred.

7. A committee shall be formed to keep points for the Year End Awards. The committee is to be composed of a chairman and two members, each from different clubs to be appointed by the president.

8. All classes will be considered open if they do not have any other specifications included - e.g. Road Hack

9. Points will be awarded in accordance with the nomination sheet.

10. All nomination sheets must be in the hands of the point keeper no later than one (1) week after they are dated.

11. All nomination sheets must be signed by exhibitor, club officer and dated.

12. Please refer to the current year's nomination form for classes counting towards award categories.

13. All ties for year end awards will be broken. (2018)

II. IN HAND DIVISION

A. Attire: refer to Attire Section of Rule Book.

B. Pony In-Hand Class: Pony In-Hand classes are split into two height divisions: 11.2 hands and under In-Hand AND over 11.2 hands In-Hand. Divisions may be shown together. No horse breeds 2 years of age and under are allowed to show in Pony In-Hand classes.

C. Open In-Hand: animals must be shown by one handler only. Breed In Hand classes, i.e. Morgan In Hand, may show their animals according to breed rules.

D. Walking Horse In-Hand or Model Class: may include Stallions, Mares and Geldings.

E. Driving Type in Hand Horse/Pony/Mini: Equine should walk into the ring with a purposeful stride. When horse breaks into the trot it should be with agility and strength of that stride. Equines should move freely. To be shown standing quietly at a square or slight reach with all four heels touching the ground.

F. Driving In Hand Horse/Pony/Mini: Equine must drive and must be shown in at least 1 driving class at 3 separate shows to be eligible for points. Any equine may enter. Points will go to their respective driving divisions.

G. Class Procedure: In hand horses shall be shown in hand and judged standing for quality, conformation and soundness. Horses shall be walked and trotted or jogged to determine lameness. Horses shall not be required to back. Way of going shall be considered. Type of horse shall be judged separately, i.e. Western, Huntseat and Saddleseat. Three sets of ribbons- one set for each type of class shall be awarded.

H. Lip chains are not allowed. Lip cords may only be used on Stallions over 1 year of age. Lip cords must be at least 3/8" in diameter. (2018)

III. FITTING AND SHOWMANSHIP

Shows offering two Fitting and Showmanship classes in one age group should state in their rules that exhibitors may receive year end points in only one of the classes. If the exhibitor shows in both classes they must designate which one they choose to count for year end points. If the exhibitor does not indicate which class they choose, the first class they enter will be the one that is pointed for year-end awards.

A. Class procedure: Enter and exit the ring at the judge's discretion. Exhibitor must lead from the near side. Horses may be posed according to breed or type. Judges should select patterns that are suitable for all breeds or types in the class. The exhibitor will be asked to work individually at the judge's direction. Exhibitor may cross the center-line of the horse.

B. Age Groups

1. Leadline F&S 5-8 years old
2. 10 years old and under
3. 11-13 years old
4. 14-17 years old
5. 18 years old and over
6. Jack Benny – 39 years old and over

C. Attire: refer to Attire Section of Rule Book.

D. Entries will be judged on:

1. The appearance of the horse or pony.
 - a. Condition: animal must be in good flesh and sound.
 - b. Grooming - clean, mane and tail free from tangles, feet properly trimmed or shod
 - c. Trimming and Braiding - appropriate for type of animal.
 - d. Tack - clean, neat and appropriate.
2. Appearance of exhibitor.
 - a. Clothes - clean, neat and appropriate.
 - b. Person well groomed, clean and alert.

3. Showing of animal in ring.
 - a. Leading
 - b. Posing
 - c. Individual performance
 - d. Showing - General - Horse or pony properly trained.
 - e. Leadsman's poise alertness and attitude.
4. This class is NOT to be judged on conformation.

SUGGESTED PATTERNS FOR SHOWMANSHIP

Patterns 1 & 2-Beginner, Academy, 10 & under, 11-13, 14-17, 18 & over

Patterns 3 & 5-11-13, 14-17, 18 & over

Patterns 4, 6, 7, 8-14-17, 18 & over

Showmanship Pattern #1

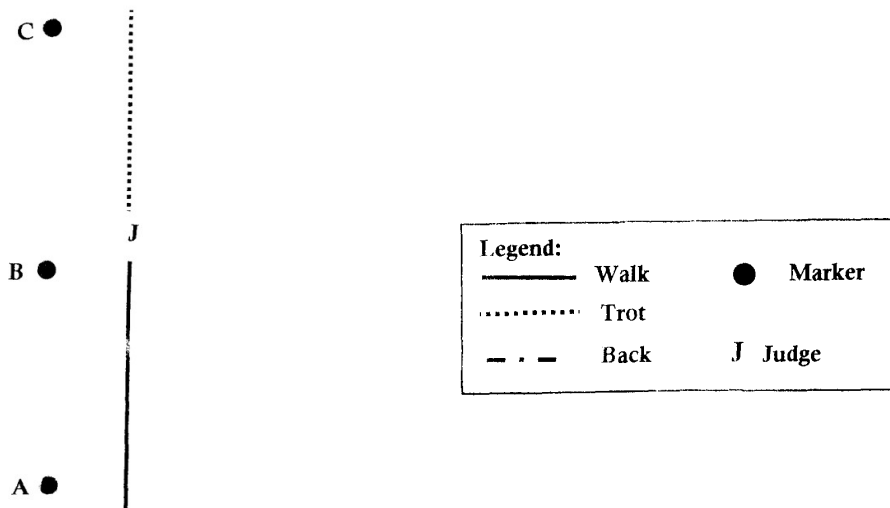

1. Start at marker a. walk to Judge at marker B
2. Halt at Judge, set up for inspection
3. After inspection, trot to marker C
4. Halt at marker C, line up at judge/ring steward direction

Showmanship Pattern #2

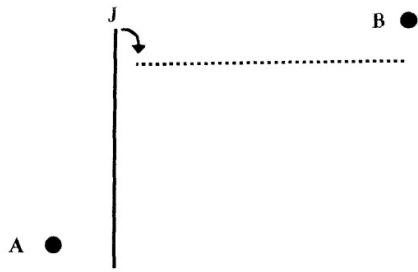

Legend:			
————	Walk	●	Marker
.....	Trot		
- . -	Back	J	Judge

1. Start at marker A. Walk to Judge
2. Halt at Judge, set up for inspection
3. After inspection turn 90 degrees to the right
4. Trot to marker B
5. Halt at marker B, line up at judge/ring steward direction

Showmanship Pattern#3

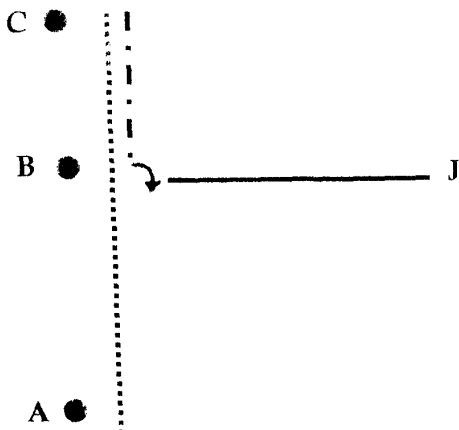

Legend:			
————	Walk	●	Marker
.....	Trot		
- . -	Back	J	Judge

1. Start at marker A, trot to marker C
2. Halt at marker C, back to marker B
3. Turn 90 degrees to the right, walk to Judge
4. Halt at Judge, set up for inspection
5. After inspection, line up at judge/ring steward direction

Showmanship Pattern #4

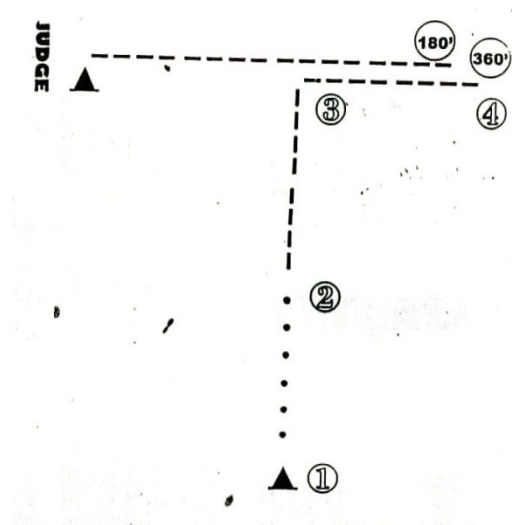

1. Walk from 1 to 2
2. Trot from 2 around 3 all the way to 4
3. Without hesitation execute 360-degree turn
4. Back three steps
5. Execute 180-degree turn
6. Trot to judge
7. Set up for inspection

Showmanship Pattern #5

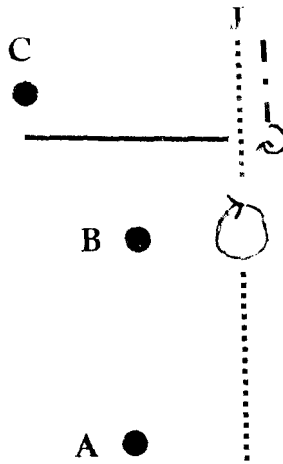

Legend:			
—————	Walk	●	Marker
.....	Trot	J	Judge
- . -	Back		

1. Start at marker A. trot to marker B
2. Halt at marker B, turn 360 degrees to the right
3. Trot to Judge, halt and set up for inspection
4. After inspection, back horse, turn 270 degrees to the right
5. Walk to marker C
6. Halt at marker C, line up at judge/ring steward direction

Showmanship Pattern #6

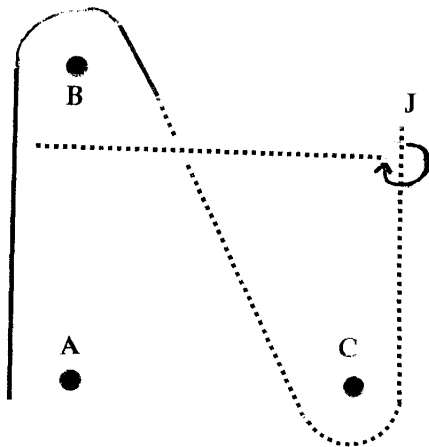

Legend:			
—————	Walk	●	Marker
.....	Trot	J	Judge
- . -	Back		

1. Start at marker A, walk around marker B
2. Trot around marker C to Judge
3. Halt at Judge, set up for inspection
4. After inspection, turn 270 degrees to the right
5. Trot past marker b, line up at judge/ring steward direction

Showmanship Pattern #8

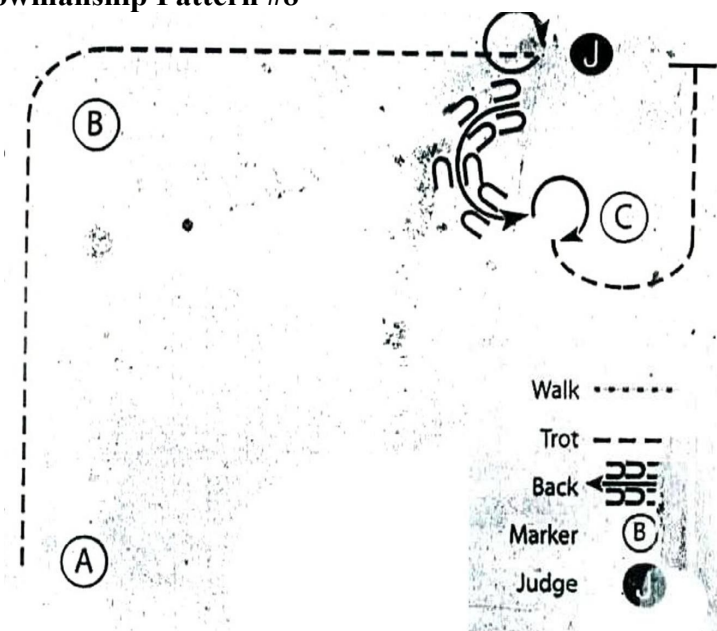

1. Trot from A to the Judge
2. Stop and perform a 360-degree turn
3. Set up for inspection
4. When dismissed back a half circle to C.
5. Perform a 270 degree turn and trot until even with the Judge
6. Stop and wait for instructions from the ring steward.

IV. WESTERN DIVISION

A. General Rules

1. Horses/ponies shall be of any breed or combination of breeds, serviceably sound and in good condition. A full mane is not required.
2. **Attire: refer to Attire Section of Rule Book.**
3. **Tack: refer to Equipment/Tack Section of Rule Book.**

A. Class Descriptions

1. WESTERN PLEASURE

Horses shall enter the ring to the right at a walk. They are to be shown both ways of the ring at a walk, jog and lope, on a reasonably loose rein without undue restraint. Entries shall be penalized for being on the wrong lead. Horses may be asked to back. Performance 80%; Conformation 20%.

Pleasure classes may be broken into specific age groups as described in the General Rules, as well as Men's Pleasure and Ladies Pleasure (limited to 18 and over). Classes may also be split into Jr. Horse 5 and under and Sr. Horse 6 and over.

2. WESTERN ROAD HACK

Horses shall enter the ring to the right at the walk. Will be asked to walk, jog, extended jog, and lope both ways of the ring. Horses must hand gallop one way of the ring. May be asked to dismount and mount. No more than 8 to hand gallop at one time. Horses may be asked to back. To be judged on performance, substance and manners. Performance 80%; conformation 20%.

3. BOSAL PLEASURE

To be judged as a Western Pleasure class. Rawhide braided or leather braided Spanish type hackamore of the regularly accepted plain type. No mechanical hackamores are permitted. Two hands on the reins are permissible. Open to any age horse. Performance 80%; conformation 20%.

4. WESTERN RIDING

Horses or pony to be worked on course as illustrated. Reasonable speed, ease of handling and changing leads throughout the pattern will be judged. Failure to follow exact course or maintain gait will severely penalize or disqualify entry. Performance 100%.

WESTERN RIDING PATTERN

On the pattern the eight small circles represent pylon markers which are recommended. These should be separated by a uniform measured distance of not less than 30 feet not more than 50 feet on the sides with 5 markers. In pattern one, the three markers on the opposite side should be set adjacent to the appropriate markers. It is recommended that markers be set a minimum of 15 feet from the fence and with 50 to 80 foot width in the pattern, as the arena permits.

A solid log or pole should be used and be a minimum of 8 feet in length.

The long serpentine line indicates the direction of travel and gaits at which the horse is to move. The shaded area represents the lead changing area between the markers. The dotted line (...) indicates walk, the dash line (---) jog, and the solid line (___) lope.

Use patterns 1 and 3 from USEF rules.

Pattern 1:

WESTERN RIDING PATTERN I

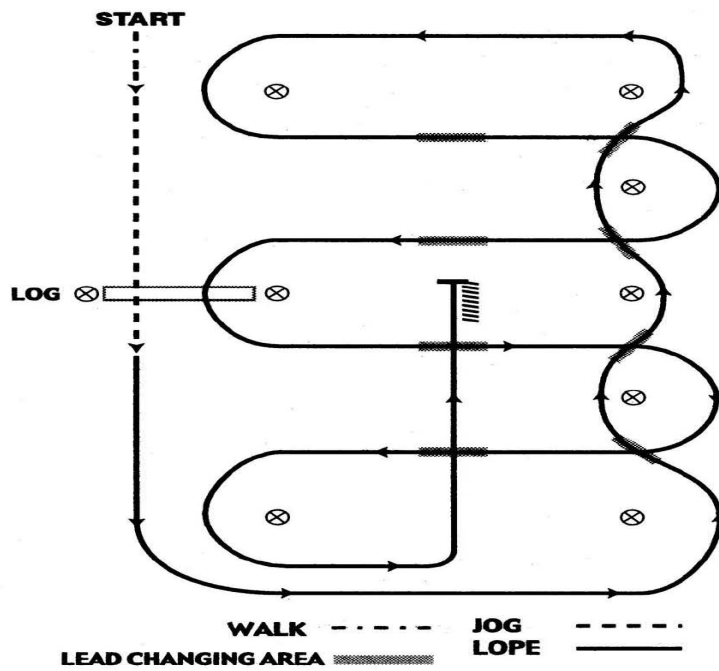

1. Walk and jog over log
2. Transition to left lead and lope around end
3. First line change
4. Second line change
5. Third line change
6. Fourth line change lope around the end of arena
7. First crossing change
8. Second crossing change
9. Lope over log
10. Third crossing change
11. Fourth crossing change
12. Lope up the center, stop and back

Pattern 3:

WESTERN RIDING PATTERN III

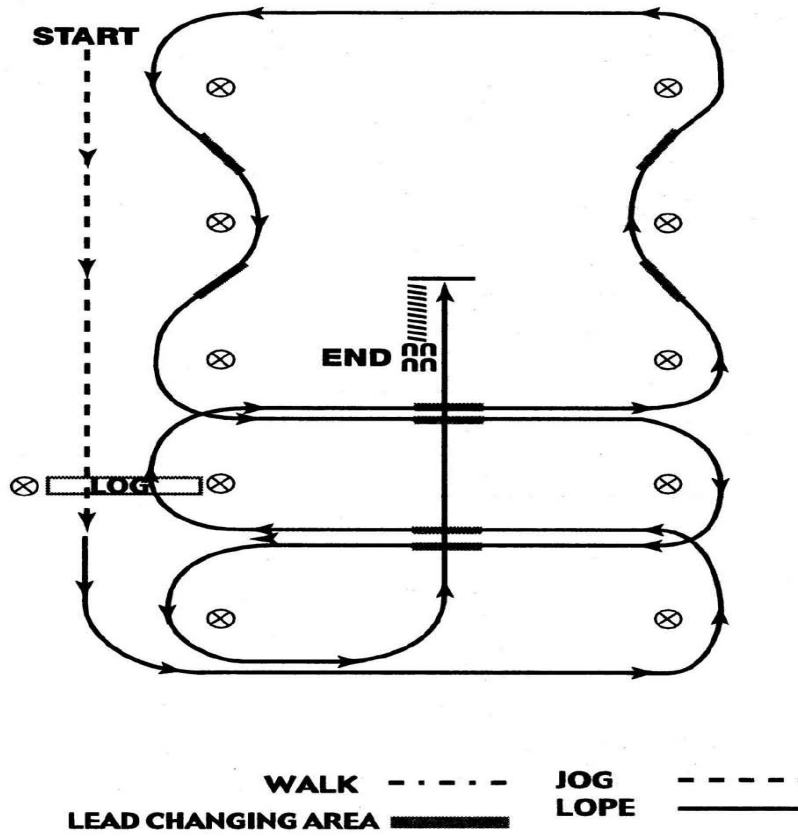

1. Walk, transition to jog, jog over log
2. Transition to left
3. First crossing change
4. Lope over log
5. Second crossing change
6. First line change
7. Second line change
8. Third line change
9. fourth line change
10. Lope over log
11. Third crossing change
12. Fourth crossing change
13. Lope up the center, stop and back

5. WESTERN REINING

Horses or ponies to be worked on course posted. Only current AQHA Reining Patterns may be used and must be posted at least four (4) classes prior to the class. Reasonable speed, smoothness of performance, execution of each routine will be judged. Failure to follow exact course or the judge's instructions will disqualify entry. Performance 100%.

Pattern 1 Western Reining

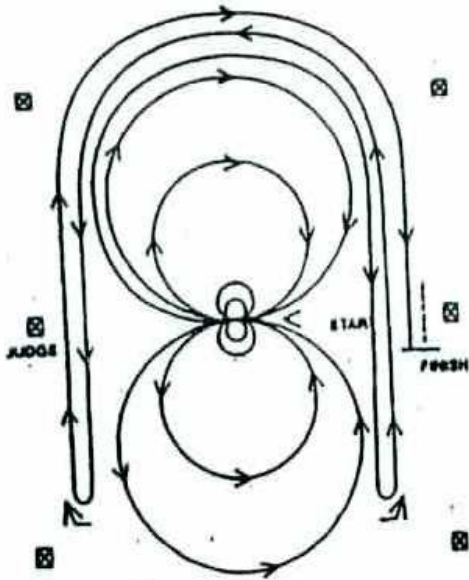

Walk horse to center of arena facing left fence or wall

- α. Complete two (2) spins to the left
- β. Complete two (2) spins to the right
- χ. Beginning on the right lead, complete two (2) circles to the right, the first being slower and smaller, the second being faster and larger.
- δ. At the center of the arena, do a simple lead change.
- ε. Begin two (2) circles to the left, the first being slower and smaller, and the second being faster and larger.
- φ. At the center of the arena, do a simple lead change.
- γ. Begin a large circle to the right, but do not close the circle. Lope down the right side of the arena past the center mark and stop. Do a left rollback.
- η. Lope back around the previous circle, but do not close the circle. Lope down the left side of the arena past the center marker and stop. Do a right rollback.
- ι. Lope back around the previous circle but do not close the circle. Lope down the right side of the arena past the center marker, stop, and back. Settle.

Pattern 2 Western Reining

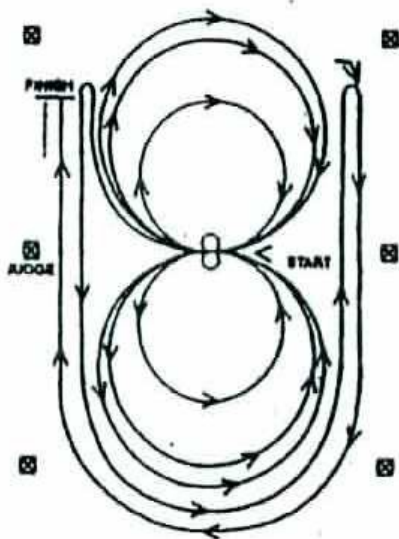

- a. Starting at the center of the arena facing the left wall, begin on the right lead completing two (2) circles, the first being larger and faster, the second being smaller and slower.
- b. At the center of the arena stop complete one (1) 360 degree turn to the right.
- c. Begin two (2) circles to the left, the first being larger and faster, and the second being smaller and slower.
- d. At the center of the arena stop complete one (1) 360 degree turn to the left.
- e. Starting on the right lead complete a large figure eight with a simple lead change in the center.
- f. Do a second simple lead change and lope on right lead down the side and stop, do a left roll back.
- g. Lope around to the other side of arena past the center mark and stop, do a right roll back.
- h. Lope around to the other side of arena past the center marker, stop and back.

Pattern 3 Western Reining

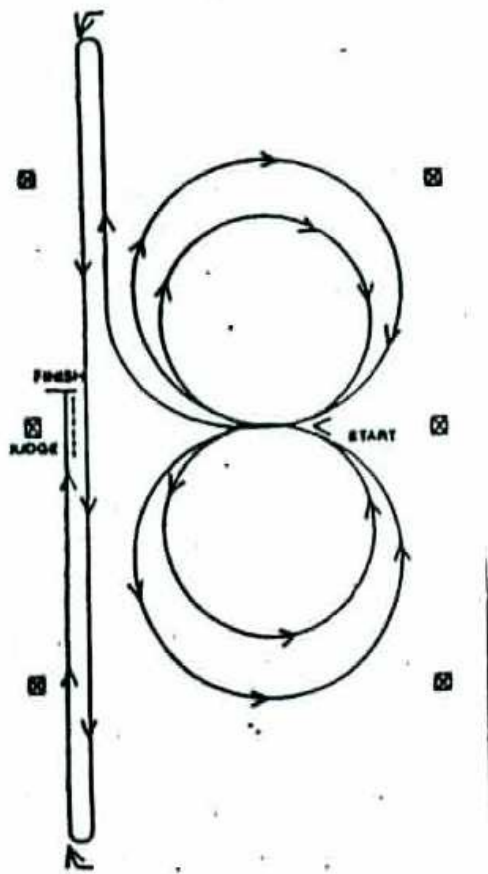

- a. Begin from a halt at the center of the arena, facing the center marker on the left wall.
- b. Lope a small, slow circle to the right.
- c. Simple change at center
- d. Lope small, slow circle to the left.
- e. Simple change at center
- f. Lope large, fast circle to the left.
- g. Simple change of lead at center.
- h. Lope large, fast circle to the left.
- i. Simple change of lead at center.
- j. Lope to the right, continuing down the rail past the end marker.
- k. Stop, rollback left to a lope.
- l. Lope beyond opposite end marker.
- m. Stop, rollback right to a lope.
- n. Lope beyond the center marker.
- o. Stop
- p. Back ten feet, settle the horse for five seconds.

Pattern 4 Western Reining

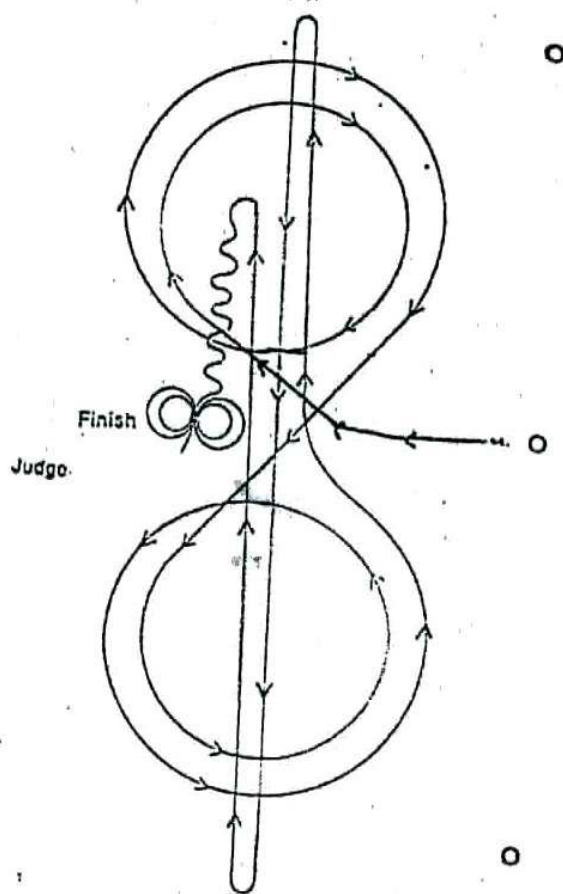

Beginning at the center of the arena facing the left wall or fence.

1. Beginning on the right lead, complete two circles to the right, the first circle small and slow; the second circle large and fast.
2. Change leads at the center of the arena.
3. Complete two circles to the left. The first circle, small and slow; the second circle, large and fast.
4. Change leads at the center of the arena.
5. Run to opposite end of arena, past end marker, and do a left rollback – no hesitation.
6. Run to opposite end of arena, past end marker, and do a right rollback – no hesitation.
7. Run past the center marker and do a sliding stop. Back up to the center of the arena (or at least ten feet). Hesitate.
8. Complete two spins to the right.
9. Complete two spins to the left.
10. Hesitate to demonstrate the completion of the pattern.
11. Walk to the judge and stop for inspection until dismissed.

6. WORKING STOCK HORSE/PONY

- a. Each participant will perform the required pattern individually and separately.
- b. Credit should be given for smoothness, finesse, attitude and control.
Deviations from the pattern must be considered as a fault.
- c. Scoring will be based on 0 to infinity with 70 denoting the average score.

Pattern #1 Working Stock Horse/Pony

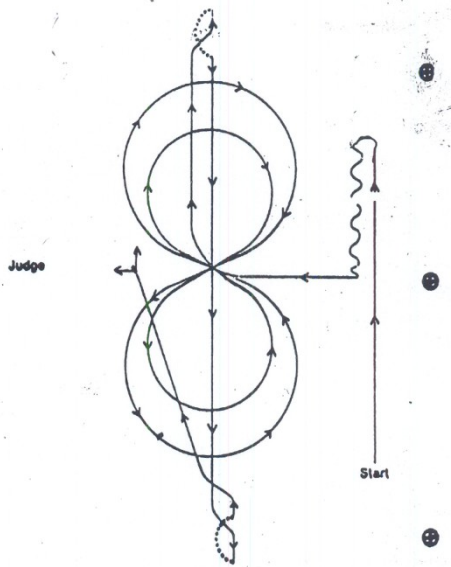

Pattern #1

Ride Pattern as follows:

1. Run past the center marker coming to a sliding stop half-way between the center and last marker.
2. Back your horse/pony to the second marker and stop.
3. Settle your horse/pony for 10 seconds.
4. Pivot horse/pony $\frac{1}{4}$ turn to the left and begin a small figure 8 to the right at a slow lope. (Simple lead changes or flying lead changes are optional; however, more credit will be given to a correct flying lead change for both figure 8's.)
5. Ride large figure 8 at a fast lope.
6. At center, turn and run down the middle past the end marker and do a left rollback-no hesitation.
7. Run to the opposite end of the arena past the last marker and do a right rollback-no hesitation.
8. Run back to center left and stop.
9. Pivot $\frac{1}{4}$ turn to the right and then $\frac{1}{2}$ turn to the left.
10. Walk to the judge for inspection until dismissed.

Pattern #2 Working Stock Horse/Pony

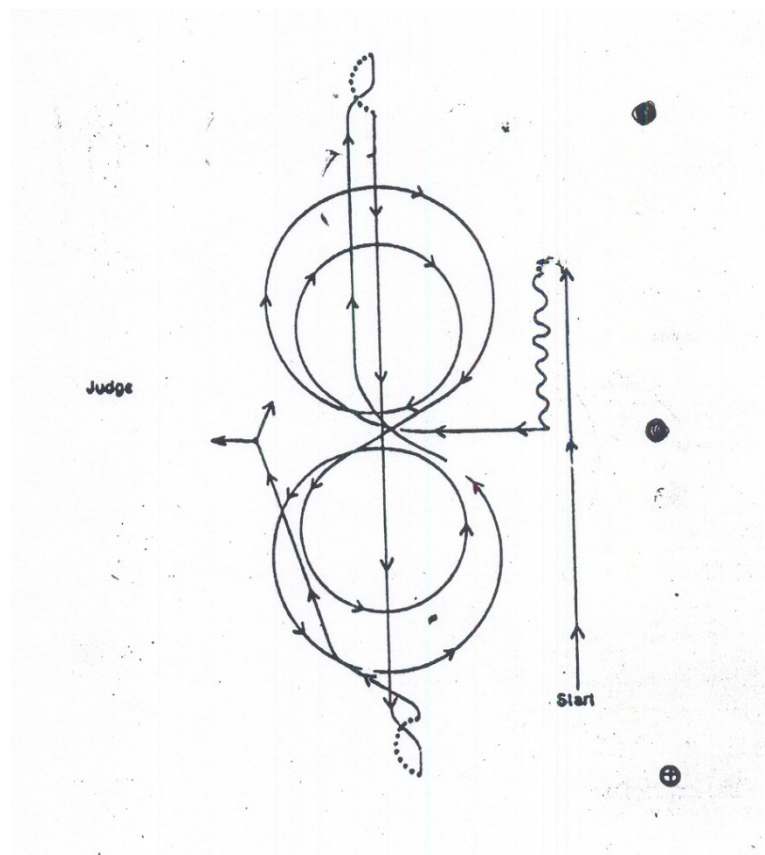

Pattern #2

Ride Pattern as follows:

1. Run past the center marker coming to a sliding stop half-way between the center marker and the last marker.
2. Back your horse/pony to the second marker and stop.
3. Settle horse/pony for 10 seconds.
4. Pivot horse/pony $\frac{1}{4}$ turn and begin on the right lead two circles to the right: the first, small and slow; the second large and fast.
5. Change leads in the center of the arena. (Simple lead changes or flying lead changes are optional; however, more credit will be given to a correct flying lead change for both figure 8's.)
6. Ride 2 circles to the left: the first, small and slow; the second, large and fast.
7. At the center marker turn and run down the middle past the end marker and do a left rollback-no hesitation.
8. Run to the opposite end of the arena past the marker and do a right rollback-no hesitation.
9. Pivot $\frac{1}{4}$ turn to the right and then $\frac{1}{2}$ turn to the left.
10. Walk to the judge for inspection until dismissed.

V. ENGLISH DIVISION

A. General Rules:

1. Horses/ponies shall be of any breed, or combination of breeds, suitable to English riding, in good condition.
2. **Tack: refer to Equipment/Tack Section of Rule Book.**
4. Huntseat **Attire: refer to Attire Section of Rule Book.**
5. Saddle seat **Attire: refer to Attire Section of Rule Book.**

B. Class Descriptions

1. THREE GAITED TRIMMED & UNTRIMMED

All horses/ponies shall enter the ring to the right at the trot. Horses/ponies to be shown at an animated walk, trot, and canter. Preference shown to horses with high action. Horses/ponies shall be reversed and shown both ways of the ring. Must be shown with either a Weymouth or Pelham bridle. Performance 80%, conformation 20%.

2. PARK TYPE SADDLE HORSE

Horses/ponies to enter the ring to the right at a trot. Horses/ponies to be shown at a graceful and animated walk, collected trot and canter. Light contact with horse's mouth must be maintained. Judged on manners, style, finish and all around brilliance. Performance 80%, conformation 20%.

3. HUNTER UNDER SADDLE

Horses/ponies are to be shown at a walk, trot and canter both ways of the ring. Light contact with the horse's mouth is required. Horses/ponies should be alert, obedient, responsive and move freely. They should not be eliminated for slight errors. Judges may ask for a hand gallop one way of the ring. No more than eight are to hand gallop at one time. Performance 80%, Conformation 20%.

4. BRIDLE PATH HACK

Open to Hunter type horses/ponies only. Horses/ponies to enter the ring to the right at the trot. Horses/ponies to be shown both ways of the ring at the walk, trot and canter. Horses/ponies must hand gallop one way of the ring. Only eight horses/ponies may hand gallop at one time. Entries should stand quietly and may be asked to back. May be asked to mount and dismount. Emphasis placed on actual suitability to purpose. No fences. Performance 80%, conformation 20%.

5. HUNTER HACK

To be exhibited at a walk, trot and canter both ways of the ring. All horses/ponies are required to jump two fences not to exceed 2'6" and gallop one way of the ring. Fences must be 36' or 48' apart with appropriate strides between and the distance between fences must be measured by a tape. Fences should be post and rail. These fences should have 2 rails and a ground rail. In the case of questionable footing, the jumps may be made into cross-rails without penalizing the horse or rider. No more than 8 horses/ponies may hand gallop at one time. Performance 80%, conformation 20%.

6. SADDLE SEAT ROAD HACK

Horses/ponies shall enter the ring to the right at the trot. Horses will be asked to walk, trot, road trot and canter both ways of the ring. Horses/ponies are required to hand gallop one way of the ring. Only 8 horses may hand gallop at one time. May be asked to back. To be judged on performance, substance and manners. Saddle seat only. Performance, 80% conformation 20%.

7. ENGLISH PLEASURE

Open to Hunter and Saddle seat type equine only. Shall enter the ring to the right at the trot. Equine to be shown both ways of the ring at the walk, trot and canter. Judged on manners, performance, quality and suitability to purpose. Loose rein upon command. Shall stand quietly and may be asked to back. Performance 80%, conformation 20%.

8. HUNT SEAT PLEASURE

Open to Hunter type horses/ponies only. Shall enter the ring to the right at the trot. Horses/ponies to be shown both ways of the ring at the walk, trot and canter. Judged on manners, performance, quality and suitability to purpose. Loose rein upon command. Shall stand quietly and may be asked to back. Performance 80%, conformation 20%.

9. SADDLE SEAT PLEASURE

Shall enter the ring to the right at the trot. Horses/ponies to be shown both ways of the ring at a walk, trot and canter. A road trot may be asked for at the discretion of the judge. Judged on manners, performance, quality and suitability to purpose. Loose rein upon command. Shall stand quietly and may be asked to back. Performance 80% conformation 20%.

10. THREE GAITED SADDLE SEAT PLEASURE HORSE

All horses/ponies shall enter the ring to the right at a trot. Horses/ponies to be shown at a walk, trot and canter. To be judged on manners, performance, quality and suitability to rider. Tack: Appropriate English saddle, Weymouth or Pelham bridle, no martingale. Loose rein on command. Horse shall be reversed and shown both ways of the ring. Horses shall stand quietly and may be asked to back. Performance 80%, conformation 20%.

VI. MISCELLANIOUS CLASS DESCRIPTIONS

1. COMMAND (OBEDIENCE)

Judged on ability of horse and rider to obey immediately the commands given by the judge at any gait. Failure to follow command is an elimination. Riders should be on their honor. Maybe broken into specific age groups as described in the general Rules, as well as in Western & English Obedience classes. Judge may ask for assistance and or spotters.

1. When 6 horses/ponies are left in the class, if two or more horses are called in on the same command at the same time, then there must be a runoff between those horses/ponies for the placing to be decided.

2. Reverse at a canter may not be called when there are more than 8 horses inside the ring, including those in the center and the judge must specify whether the exhibitors must change or stay on the same lead.

3. When horses/ponies are being excused, those on the rail may stand at ease.

4. Bucking is a disqualification.

2. DISCIPLINED RAIL

A command class, but not a “fault and out” class. The class may be broken into specific age groups as described in the general rules, as well as into English or Western classes. Purpose is to show ability of a highly trained horse. All horses to enter the ring and are shown together with no individual work-out except in the event of a tie. Should the number of entries warrant, more than one go-round shall occur to determine the finalists. Each go-round shall require the exact same sequence of work performed. Once the finalists are determined a final go-round will occur and the judge may change the work order and/or add additional commands. The class is placed to six places. The class is to be judged on performance, ability, response and attitude of the horse. The judge shall be positioned to view the complete arena by standing at one end or in a corner or out of the arena, when possible, to view as many entries as possible during the class.

3. SIT A BUCK

Upon entering the ring each contestant receives a simulated buck which shall be placed on the left side under the buttock. One half of the buck must be showing at all times. Loss of buck - contestant shall proceed to the center of the ring. No chaps shall be worn. Contestants shall follow the commands of the ringmaster.

4. TRAIL DIVISION

1. Open to horses or ponies. Open trail class shall work over and through obstacles. If a gate is used, the handle should be approximately 48 inches from the ground. Rider may be asked to open gates, carry objects from one part of the arena to another, ride through water, over logs or simulated brush, ride down into and up out of a ditch without lunging or jumping, cross over a bridge, back through obstacles, mount and dismount from either side and perform over any natural conditions encountered along a trail. No less than five obstacles may be used.

2. Trail class jumps are limited to 18 inches in height.
3. Animals may be shown at a walk, trot or jog, or equivalent gait, lope or canter, both ways of the ring on a reasonably loose rein without undue restraint. Entries shall be penalized for being on the wrong lead. Special emphasis shall be placed on the walk; Trail Course must be posted by the show committee for the exhibitors to view at least one class in advance of the class. Trail may be broken into specific age groups as described in the General rules as well as ladies' or men's trail class, or Western, English, Pony, and Walker.
4. Schooling at the discretion of the show committee.

5. COMBINATION ENGLISH AND WESTERN PLEASURE

Riders shall show English first. Horses/ponies will be shown at a walk, trot and canter both ways of the ring and line up in the center of the ring. Two attendants are permitted to assist the rider in changing to western tack. English and Western riders may be different. When all tack is changed, riders will remount when directed to do so by the Judge and show Western both ways of the arena at a walk, jog and lope. Horses/ponies must stand quietly in line and may be asked to back. To be judged equally on performance, manners and way of going English and Western.

6. COSTUME CLASS

Entries must enter the ring at a walk counter-clockwise, may be led, ridden or driven. Costumes must be consistent with the theme represented. Exhibitors should provide the announcer with a written description of their costume. Entries may be judged on their beauty, authenticity, humor or originality.

7. JACK BENNY CLASSES

Classes for riders 39 years of age and over, to include any Jack Benny specified classes except bosal. These are to be fun classes including all seats: English, Western and Walker. Ponies are also eligible.

8. ACADEMY CLASS

Riders may not cross enter in any other class. Riders who show out of the Academy Division are not eligible to return to the Academy Division. Once a rider has shown in a walk/trot/jog/canter/lope class a return to a walk/trot/jog class is prohibited. Horses are to be of lesson type. These horses must display the characteristics of such. These classes are for growing and learning experiences and exposure to horse shows.

A. General Rules

1. All Academy Equitation classes are to be judged on the ability of the rider to control and show his/her horse. Academy equitation classes are to be judged on basic equitation skills with correct diagonals and leads.

2. In Academy pleasure classes, the horse/pony should be of lesson type. It is to be judged on its ability to give the rider a safe pleasurable ride. Control-ability should be of utmost importance.

3. No more than 8 horses/ponies may canter or lope at one time.

4. Standard classes are:

a. Walk/trot/jog equitation (any age or age specific)

b. Walk/trot/jog/pleasure (any age or age specific)

c. Walk/trot/jog/canter/lope equitation (any age or age specific)

d. Walk/trot/jog/canter/lope pleasure (any age or age specific)

e. Academy Leadline - to be judged on the ability and presence of the rider.

Rider is judged on seat, hands, and general control of his/her mount. Schooling tack may be used. May not cross enter with regular leadline. Horse/pony to be led with lead attached **to a halter (not a bridle)** by a leader 14 years of age or older. Horses/ponies to be of lesson type.

5. Riders who show out of Academy may not go back to academy division.

For Attire and Tack requirements (by seat), refer to Attire Section and Equipment/Tack Section of /Rule Book. PROTECTIVE HEADGEAR IS REQUIRED FOR ALL ACADEMY PARTICIPANTS.

9. LEADLINE:

A. General Rules

1. Riders to be 3-8 years of age.

2. Horses/ponies to be led by a competent leader 14 years of age or older with a lead attached **to a halter (not a bridle) in all seats.**

3. Leadline Equitation and Pleasure classes may be split Huntseat, Saddle seat and Western with a separate entry sheet and judges card to be used.

4. If a jog/trot or equivalent gait is requested each horse/pony shall be worked individually.

5. Leadline riders may not be asked to back their horse/pony.

6. Leadline riders under the age of 5 are not eligible for any other class.

7. Leadliners 5-8 are eligible to compete in Fitting & Showmanship Leadline.

8. Protective headgear is required for all leadline participants. **For additional attire requirements (by seat) for both exhibitor and handler, refer to Attire Section of Rule Book.**

9. Over the horn stirrups may be used in leadline classes

10. Leadline exhibitors may only compete in classes specifically designated as leadline.

B. Acceptable Classes

1. Leadline Equitation: To be judged on the ability and presence of the rider. Rider is judged on seat, hands, and general control of his/her mount.

2. Leadline Pleasure: To be judged on the horse/pony's ability to give the rider a safe, pleasurable ride. Controllability and safety should be of the utmost importance.

3. Leadline Showmanship: Leadliners must be accompanied by a competent exhibitor 14 years or older who must have a separate lead attached to the horse. Horses/ponies to be shown in a halter. May not cross enter any other Fitting and Showmanship class.

4. Leadline Trail: Must be held in a closed ring with no more than four (4) obstacles. Acceptable obstacles are: Figure eight obstacle around cones and/or serpentine; walk through line of cones, stop, reverse and walk to another cone; walk over ground poles; step into a box made of poles and make a 360' turn; stop at judge to answer questions. Absolutely no trotting or backing through or over obstacles. May trot between obstacles. May be asked to back at handler's discretion.

10. GREEN, BEGINNER, FIVE & UNDER DIVISIONS

A. Green Horse: A green horse is in its first or second year of showing under saddle. Classes **must** be either two-gait or three-gait and **entrants may not cross enter between two-gait and three-gait classes.** (2018) Green horse classes would include In-Hand, trail, pleasure or any other performance class specified as green horse. Green horses being shown western may be ridden in a snaffle bit or bosal regardless of age. They will not be eligible for any other riding classes except Gymkhana/Games Classes and any class that is a non-pointed class. No age restrictions on horses eligible for this division. No Beginner Riders may show in the Green Horse division. A Green Horse year end division award will be offered.

B. Beginner Rider: Rider is in his/her first or second year of showing in a walk/trot/jog/canter/lope class. A return to a walk/trot/jog class is prohibited. No stallions allowed. Beginner exhibitors are not eligible for any other classes except Fitting and Showmanship, In Hand, Driving, and age group equitation and pleasure.

1. Standard classes are:

- a. Equitation (any age or age specific)
- b. Pleasure (any age or age specific)
- c. Fitting & Showmanship (any age or age specific)
- d. Trail (any age or age specific)

STATUS IS DETERMINED BY DATE OF SHOW

C. Five & Under: Also known as a Junior Horse. Any equine 5 years old or less. Eligible for 5 and Under, youth and open classes. Snaffle bits and bosals are permitted.

D. Attire requirements for Green Horse, Beginner Rider and Five & Under Division: refer to Attire Section of Rule Book.

11. 12-17 and 18 and OVER WALK/TROT/JOG/ALTERNATE GAIT (W/T/J/AG)

A. 12-17 W/T/J/AG and 18 and Over W/T/J/AG: classes will include both equitation and pleasure classes but entries cannot cross enter Walk/Trot/Jog Canter/Lope. There is no limit on how many years exhibitors may ride in these classes.

These exhibitors are allowed to show in all W/T/J/AG gait classes, In-Hand, Fitting & Showmanship and Driving.

B. **Attire: refer to Attire Section of Rule Book.**

12. 11 and Under WALK TROT JOG OR ALTERNATE GAIT (W/T/J/AG)

A. General Rules

1. Open to riders 11 and under.
2. Horses or ponies to enter the ring at a walk.
3. Riders are judged on seat, hands and general control of mount.
4. Horses or ponies must walk and trot or alternate gait both ways of the ring, stop at judge's signal and back at judge's discretion. However, Saddle Seat may not be asked to back.
5. Entries are not eligible for any other equitation or performance class except classes labeled Walk Trot/Alternate Gait or Jog/Alternate Gait, In Hand, Fitting and Showmanship, Costume Class, Driving and Gymkhana 10 and under.
6. Any rider riding in Walk Trot/ Alternate Gait 11 & under may not enter any Walk Trot Canter class regardless of the horse they are riding. Once an exhibitor rides in a Walk Trot/Jog Canter/Lope class he/she may not show in Walk Trot/AG or Jog/AG again.
7. All Huntseat Walk-Trot/Alternate Gait Equitation and Pleasure classes, Saddle seat Walk-Trot/Alternate Gait Equitation and Pleasure classes, and Walk-Jog/Alternate Gait Equitation and Pleasure classes must be split and have separate judge's cards and entry sheets.
8. Headers are allowed in the ring once the exhibitors are lined up at the ring master's direction.
9. Protective headgear is required for all participants. For additional attire requirements (by seat) refer to General Rules VII.

VII. EQUITATION DIVISIONS

If a judge is planning to use an equitation/horsemanship workout or pattern it must be posted at least one hour prior to the class or prior to the start of the show. It is the judge's option to test individually after the rail work has been completed. Said workout or pattern must be a combination of approved tests as established by NYSSHA. The judge may announce to the exhibitors the details of the workout and answer any questions they might have to clarify the workout. If a pattern is required and has not been posted it must be announced to the exhibitors and over the loudspeaker.

For Attire and Tack requirements (by seat), refer to Attire Section and Equipment/Tack Section of /Rule Book.

1. WESTERN HORSEMANSHIP (EQUITATION)

A. General Rules:

1. Classes are to be broken into specific age groups as described in the general rules.
2. Riders enter the ring to the right at a walk and are judged on seat and hands and general management and control of mount at a flat footed four beat walk, two beat jog and three beat lope both ways of the ring.
3. Riders may reverse either by turning toward or away from the rail.
4. Judges may call for more tests to be performed by competitors considered for an award.

B. Tests from which judge may choose

1. Back in line up.
2. Questions regarding basic tack and horsemanship.
3. Circle at the jog.
4. Figure 8 at the jog.
5. Lope and stop.
6. Figure 8 at the lope demonstrating simple change of lead. Horse is brought back to walk or jog and asked for the other lead.
7. Figure 8 at the lope demonstrating flying change of Lead.
8. Change leads down center demonstrating simple change of lead
9. Ride serpentine course demonstrating simple changes of lead.
10. Ride serpentine course demonstrating flying change of lead.
11. Demonstrate 180 degree turn on the haunches.
12. Demonstrate 360 degree turn on the haunches.

Judge may choose: tests 1 thru 3 for walk/trot & maiden riders; tests 3 thru 5 for 13 & under, novice & limit riders; tests 1 thru 12 for 14-17, 18 & over and open riders.

2. BAREBACK HORSEMANSHIP

Same rules govern this class as govern the Western Horsemanship class.

3. HUNT SEAT EQUITATION

A. General Rules:

1. Classes to be broken into specific age groups as described in the General Rules.
2. Exhibitors shall enter the ring to the right at a trot and continue around ring at each gait (walk, trot and canter) and on command reverse and repeat.
3. Riders shall be judged on seat and hands and general management and control of mount. Light contact with horse's mouth is required.
4. The order to reverse can be done by turning either toward or away from the rail.
5. Riders may be asked to work collectively without stirrups in 14-17, 18 and over age groups and open classes.
6. Judges may ask the top competitors to perform at least two of the appropriate tests listed below.

B. Tests from which judges may choose

1. Back in line up.
2. Questions regarding basic horsemanship, tack and equipment and conformation.
3. Circle at a trot.
4. Figure 8 at a trot demonstrating change of diagonals.
5. Canter and halt. (4-6 sec.).
6. Work collectively at the walk, trot and canter.
7. Figure 8 at a canter demonstrating simple change of lead. Figures to begin in center of 2 circles so 1 change is shown.
8. Ride without stirrups, or drop and pick up irons.
9. Dismount; and mount individually,
10. Turn on the forehand
11. Figure 8 at a canter on correct lead demonstrating flying change of lead.
12. Execute a serpentine at a trot and/or canter demonstrating simple or flying changes of lead.
13. Change leads on a line demonstrating a simple or flying lead change.
14. Canter on the counter lead. (No more than 8 at a time)
15. Turn on the haunches from a walk - 2 or 1/4 turn.

Judge may choose: tests 1 through 3 for walk, trot and maiden riders; tests 1 through 6 for novice, limit and 13 & under riders; tests 1 through 15 for 14-17, 18 & over and open riders.

4. BAREBACK EQUITATION

Same rule as Hunt Seat or Saddle Seat Equitation.

5. HUNT SEAT EQUITATION OVER FENCES

A. General Rules:

1. Should be split into age groups, with 13 and under not to exceed 2'3".
2. Judged as an Equitation Class. There shall be 6 to 8 fences 2'0" to 2'6". Cannot be raised. All fences that are post and rail should have 2 rails plus a ground rail. Lines of fences including In and Outs must be set at measured distances, measured by a tape measure. Lines must be set at a minimum of 36 feet and if the distance is greater than 36 feet it must be divisible by 12 (ex: 48, 60, and 72).
3. Equitation over Cross-Rails – Riders to jump only cross-rails and may not cross enter to straight rail classes. Horses to jump a course of 6-8 fences and the course may show a change of direction.”

6. SADDLE SEAT EQUITATION

A. General Rules:

1. Classes to be broken into specific age groups as specified in the general rules.
2. Riders enter the ring at the trot, turn to the right and proceed counterclockwise. The class proceeds around the ring at each gait (walk, trot and canter) and on command will reverse and repeat.
3. The order to reverse may be executed either by turning toward or away from the rail.
4. Entries will line up on command.
5. Judges may ask for at least 2 of the tests listed below from the top competitors.

B. Tests from which judges may choose:

1. Pick up reins in line up only.
2. Circle at a trot.
3. Questions regarding basic horsemanship, tack and equipment and conformation.
4. Drop and pick up irons in line up only.
5. Change of diagonals down center line or on rail
6. Figure 8 at a trot demonstrating change of diagonals
7. Back for not more than 8 steps.
8. Execute a serpentine at a trot on the correct diagonal
9. Circle at canter on the correct lead.
10. Figure 8 at a canter demonstrating simple change of lead. Horse is brought back to a halt/walk before asking for the other lead.
11. Serpentine at a canter with simple change of lead.
12. Change leads down center or on rail demonstrating simple change of lead. Judge specifies exact lead changes to be done and the beginning lead.
13. Ride without stirrups for a short time. No more than one minute at the trot. Pick up irons at the halt or walk.

Judge may choose: tests 1 thru 3 for walk trot & maiden riders; tests 1 thru 9 for novice, limit & 13 & under riders; tests 1 thru 13 for 14-17, 18 & over riders.

VIII. MINIATURE HORSE DIVISION

Equines 38” and under must show as miniature horses or as a pony. They may not cross enter with the pony division.

Height: A miniature horse must be 38” or less in height. The height verification of the miniature horse shall be determined by measuring the vertical distance from the base of the last hairs of the mane to the ground with the front two legs vertical and in line with or parallel to the measuring device, and the back of the hocks in a vertical line with the horse’s buttocks. The last hairs of the mane refer to the last coarse (longer) hair of the horse’s mane. The horse’s head and neck must be in a natural position. The animal must stand squarely on all four feet.

General Impression: A small, sound, well-balanced horse, possessing the correct conformation characteristics of most breeds-refinement and femininity in the mare, boldness and masculinity in the stallion. The general impression should be one of symmetry, strength, agility and alertness. A miniature horse should give the feeling of just that, a miniature horse, not a pony.

Braiding, tying of mane or tail, and ribbons may be used in Liberty class only. Horses do not need to be clipped and will not be penalized. However, regardless of hair length, the horse should be clean and trimmed appropriately for the horse’s body style.

1. IN HAND CLASSES

A. Miniature Horse In-Hand:

1. Horses to be shown in hand at the walk and trot. Horses must also be viewed in motion from the side and judged on the priority of: conformation according to body type, way of going, and overall presentation (in that order). Teeth may be checked at judges discretion.
2. Obstacle Driving patterns to be posted in the rule book.

B. Miniature Horse/11.2 and under Multi Color/Solid Class:

In color classes, horses are to be judged 100% on the natural coloring of the horse. No other factors are to be considered. Horses to be shown both ways of the ring at the walk. The class to be divided as:

1. Multi Color: open to miniatures with Pinto (the presence of white behind the eye or above the knees/hocks) and Appaloosa coat color characteristics.
2. Solid Color: open to all others.

2. PERFORMANCE CLASSES (A horse will be exhibited by only one handler per class.)

A. Showmanship Classes: Class specifications listed in the general section of the NYSSHA rule book. Miniature Horse exhibitors are to be dressed in neat, clean clothing. Suitable gloves are encouraged. Suitable hat and footwear is required.

3. OBSTACLE IN-HAND CLASSES

A. Class to be judged on performance and way of going with emphasis on manners throughout the course. Entries will be evaluated on responsiveness and willingness, plus general attitude.

B. Any obstacle that is a step over cannot exceed 12'' in height.

C. Any baiting in such class is a disqualification

D. Obstacle Guidelines: Ingenuity and originality in adapting and combining various obstacles are encouraged. However, all obstacles should be safe for exhibitors as well as horses. Suggested obstacles include:

1. Back through or out of obstacle
2. Walk through water or simulated water
3. Put on and remove equipment from person or horse
4. Walk through a narrow passage
5. Pick up an object and place it in a designated location
6. Walk across a bridge or simulated bridge
7. Walk pattern created with poles, pylons, (figure 8, serpentine, cloverleaf, etc.
8. Ground tie horse in a circle
9. Side-pass

E. Horse to be shown in a halter with lead. Horse may not be touched by the exhibitor unless the judge or course designer instructs or if side passing is required. Whips or crops are prohibited. Tying up of long tails is permissible.

F. Judge/Course Designer may walk the course with exhibitors (without horses) prior to judging.

G. No jumps will be allowed.

4. OBSTACLE GROUND DRIVING CLASSES

A. Class to be judged on performance and way of going with emphasis on manners throughout the course. Entries will be evaluated on responsiveness and willingness, plus general attitude.

B. Horses to be 2 years old or older to show in Obstacle Ground Driving.

C. Obstacle Guidelines as in Obstacle/Trail In Hand Classes.

D. **Tack: refer to Equipment/Tack Section of Rule Book.**

E. A horse entered in ground driving class may not cross-enter with any driving class.

5. MINIATURE HORSE HUNTER or JUMPER CLASSES

A. General Rules:

1. There will be a minimum of 16' between jumps except for an in and out which should be set at approximately 12' apart.

2. Fences to be constructed of light-weight materials which can be easily knocked down, i.e. PVC piping, wooden posts no greater than 2 inches in diameter, etc. Jumps must be a minimum of 5 feet wide, and uprights a maximum of 48'' in height. A ground pole must be used for any rail jump.

3. Horses must be 3 years old or older to participate in any over fence class.

B. Miniature Horse Hunters

1. Judged on style, manners and way of going with preference given to those horses that cover the course at an even pace, with free-flowing strides, as in a brisk trot or canter, but must maintain same gait throughout the course. Circling once upon entering the ring and once upon leaving the ring is permissible. Hunter must demonstrate at least one, but no more than four changes of direction. Charging fences, or not maintaining the same gait throughout the entire course shall be penalized.
2. Jumps must be a minimum height of 18" and a maximum of 24". Ground poles are required. There will be a minimum of 4 obstacles, and horses are to make a minimum of 6 jumps and a maximum of 8 jumps.
3. Major faults to be considered are: knockdowns, touched, refusals, bucking or kicking, spooking or shying, showing obstacle to the horse or wringing the tail.
4. Causes for elimination: 3 refusals, off course, crossing your own path, fall of horse/exhibitor, jumping of obstacle by exhibitor, carrying of whip, unsound horse.
5. The type of exhibitor footwear may include any athletic type shoe.

C. Miniature Horse Jumpers

1. To be scored mathematically, based on faults incurred between the starting line and the finishing line. Circling once upon entering and once upon leaving the ring is permissible, but not after crossing the starting line.
2. Minimum height for jumps must be 18", maximum height 28".
3. Exhibitor may not go over the jumps with the horse. Whips are permitted, and the exhibitor's type of footwear **may** include any athletic type shoe. Front leg wraps and/or boots are optional.
4. Jump-offs are to occur for the first place between horses that tied for first place only. The jump-off will be held over the original course. The number and location of the jumps are to remain the same as well as the path of the course to be taken. Final determination is the combination of least faults and fastest time of the jump-off.
5. Scoring: knockdown 4 faults, refusal 3 faults, circling after crossing starting line 3 faults, crossing own path 3 faults.
6. Causes for elimination: 3 refusals, off course, fall of exhibitor/horse, jumping of jump by exhibitor, failure to pass through the start and/or finish cones or knocking such cones over.

6. MINIATURE DRIVING CLASSES

A horse entered in any driving may not cross-enter with any ground driving class. All other driving rules apply.

IX. LIBERTY DIVISION:

1. **Liberty is to demonstrate the natural beauty of the equine. Horses/Ponies/Minis to be judged on style, grace, animation, gaits, presence, music suitability and ease of catching.**
2. **The Horse/Pony/Mini must be at least one year old to be entered in Liberty.**
3. **Horses/Ponies/Minis will be judged beginning when the halter is removed by the exhibitor (person wearing the number) and until caught by the exhibitor. Time of Liberty shall be 1.5 minutes; time to catch shall be 1.5 minutes.**
4. **Only the exhibitor and one handler will be allowed in the arena with the equine. Whips and shaker bottles are allowed, but touching the equine during the performance with aids or hands will result in a disqualification.**
5. **Horses/Ponies/Minis must be caught and haltered by only the exhibitor (not the helper) within 1.5 minutes or will be disqualified.**
6. **Music is required. Suitability of equine's movements to the chosen music must be evaluated.**
7. **No assistance from outside the arena will be permitted. It is suggested that the shows announce this before the class is in session.**
8. **The following points ratings must be used when judging Liberty: Style and Grace 20 points, Animation and Presence 20 points, Gaits 20 points, Music and Suitability 20 points, Catch 20 points for a total of 100 possible points**
9. **Baiting of equine to encourage the animal to perform is not allowed. Baiting at any time, including the catch portion is a disqualification.**
10. **Proper attire is required (refer to In Hand Division Attire).**

X. DRIVING DIVISION

A. General Rules

1. Pony Driving split into two divisions: 11.2 hands and under AND over 11.2 hands. Divisions may be shown together, but if so, will pin separately.
2. Driver's attire to be neat and appropriate to vehicle shown. Bare shoulders are not appropriate.
3. Any persons removing the bridle from a horse/pony/mini that is hitched to a driving vehicle will be disqualified from the show.
4. Any persons hitching a horse/pony to a driving vehicle without first putting the driving bridle on, will be disqualified from the show.
5. Shown to a suitable 2 or 4 wheel vehicle. (Harness to be suitable to vehicle used.) Driver is responsible for the safety of Harness and Cart being in good working order.
6. **Tack: refer to Equipment/Tack Section of Rule Book.**
7. One attendant (header) without whip is optional when horses/ponies/minis line up.
8. Horse and ponies may be shown together.

1. PLEASURE DRIVING

A. General Rules

PLEASURE DRIVING CLASS: HORSE/PONY/MINI CLASSES MUST BE SHOWN SEPARATELY.

To be shown both ways of the ring at a walk, pleasure trot, and extended trot. Stand quietly and to rein back. To be judged 60% on performance, manners and way of going, 30% on the condition, fit and appropriateness of harness and vehicle and 10% on neatness, appropriateness of attire and overall impression. Excessive speed will be penalized.

1. Walk: A free regular and forward moving 4 beat gait. The horse should walk energetically but calmly and determined pace.
2. Pleasure Trot. Horse/pony/mini should maintain forward impulsion while showing submission to the bit. The trot is slower and more collected, but the horse/pony/mini should indicate willingness to be driven on the bit while maintaining a steady cadence.
3. Extended Trot: This is a clear, but not excessive in gait and length of stride. The horse/pony/mini goes forward freely, engaging the hind legs with good hock action, on a taut light rein, the position balanced and unconstrained.

2. COMBINATION RIDE AND DRIVE

Horses/ponies may be shown together

(single entry to be shown in two concurrent sections.)

A. General Rules

1. The turnout may not leave the arena once the judging has begun.
2. Up to two attendants ARE permitted to assist with unharnessing and saddling.
3. Driver and rider may be different.
4. Riders may not mount until told to do so by the judge after all vehicles have left the ring.
5. To be judged equally on performance, manners and way of going in harness and under saddle.
6. Horses/Ponies will be governed by the same rule.

B. In Harness: Entries to drive first following the Pleasure Driving Rule

C. Under Saddle: To be shown both ways of the arena at a walk, trot and canter or walk, jog and lope. To stand quietly. May be asked to back.

3. OBSTACLE DRIVING (Horses/Ponies/Minis may show in the same class.)

A course diagram shall be posted at least one hour prior to the start of any obstacle driving class. To be judged under the same general concept as a ridden trail class, but exhibitors must not be required to drive over logs or cavaletti, open gates, or perform any other task deemed potentially hazardous to horse or vehicle. Course design should take into effect that horses/ponies/minis may show in the same class. Entries may be required to walk and/or trot only. A break to canter of more than 3 strides shall be penalized. Three refusals will cause elimination from an obstacle. This class is not to be timed.

Pattern #1



Pattern#2

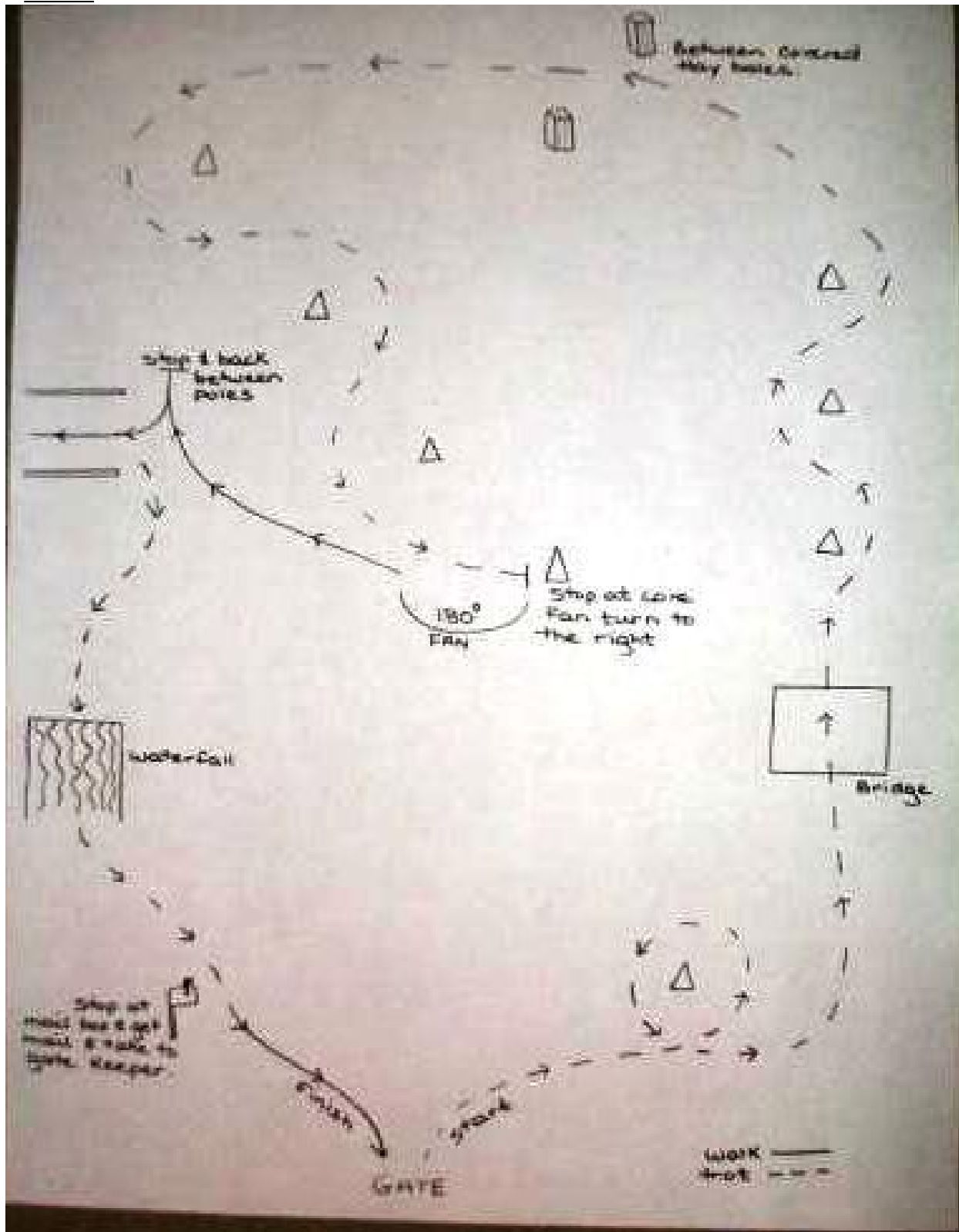

4. TIMED OBSTACLE DRIVING

A separate timed obstacle class, utilizing cones and balls only, and run in accordance with American Driving Society guidelines, may be included, but horses and ponies may show together.

5. REINSMANSHIP

To be judged on the driver's ability to control the horse, pony or miniature. No rail work is required. The judge shall ask each driver to execute an appropriate test. Horses, ponies and miniatures may show together. If the rail work is desired Horses, Ponies, and Mini's must work the rail separately.

6. DRIVING QUADRANGLES

Horses, ponies and miniatures to show together. Entire course must be at a trot. There is a 10 second penalty for cantering. Time starts when you cross the start/finish line. You make a left turn around each upper cone, go back through the center, and make a right turn around each bottom cone. Go back through the center and cross the start/finish line to stop your time.

Pattern:

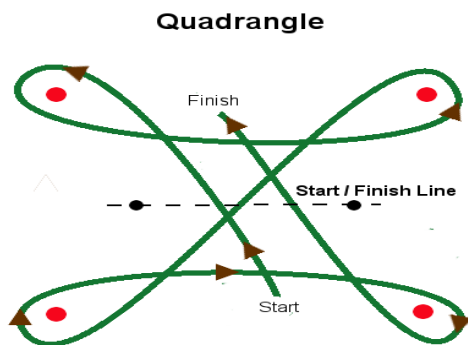

7. COUNTRY PLEASURE DRIVING Divided into Horse, Pony and Miniature division. They must show separately.

Country Pleasure Driving Horses/ponies/minis are to enter the ring counterclockwise at a country pleasure trot. To be shown both ways of the ring at a walk, country pleasure trot and extended trot. To stand quietly and to rein back. To be judged 60% on performance, manners and way of going, 30% on the condition, fit and appropriateness of harness and vehicle, and 10% on neatness, appropriateness of attire and overall impressions. Over-checks and side-checks should be slightly loose, not snug. The head set should appear natural for the horse. Excessive knee action and speed to be penalized.

a. Walk: A free regular and forward moving four beat gait. The horse/pony/mini should walk energetically, but calmly, with an even and determined gait.

b. Country Pleasure Trot: A balanced, easy moving, relaxed two beat gait demonstrating forward movement.

c. Extended Trot: A clear increase in gait and length of stride. The horse/pony/mini should move freely on a taut but light rein, while maintaining a balanced gait and forward movement. Excessive knee action and speed shall be penalized.

XI. HUNTERS AND JUMPERS OVER FENCES (HORSES/PONIES)

1. OPEN AND JUNIOR JUMPING

Jumpers shall follow Table I of the USEF (USA Equestrian) rules.

XII. HUNTER DIVISION (HORSES/PONIES)

A. General Rules

1. Schooling: Schooling over any obstacles in the ring or over any part of an outside course may be permitted only at the time specified by the show committee. All other schooling will be permitted only within clearly identified areas and at times designated by the show committee.

2. 1st and 2nd year Hunter: A 1st and 2nd year Hunter is a horse/ pony of any age that is in his first or second year of showing over fences. Performance 100%

3. Regular hunter or Regular Working Hunter: A regular hunter is a horse/pony of any age, which is not restricted by previous showing in any division. Performance 100%

4. Low Hunter or Low Working Hunter - A hunter that jumps no more than 2' to 2'3". Performance 100%

Horses/ponies may be jogged for soundness in the above 3 sections after the class if the judge desires but will not be asked to strip.

5. Conformation Hunter – a hunter that is judged 25% on conformation and the course may be set at heights consistent with other classes at the show. The conformation hunter can be any age and is not restricted by previous showing in any other division. Must be judged for conformation after the class and may be jogged for soundness.

6. Handy Hunter: In Handy Classes obstacles should simulate those found in trappy hunting country. The course should have 2 changes of direction and at least one combination as well as three of the following: hand gallop a jump, bending line, rollback turn, fence at the end of the ring, trot over one obstacle or lead over one obstacle.

7. Hunter Over Cross Rails: Horses/Ponies to jump only cross-rails and may not cross enter to straight rail classes. Horses/Ponies to jump a course of 6-8 fences and the course may show a change of direction.

8. Type (course)a. A hunter course shall be a course of 6 to 8 natural obstacles simulating obstacles found in the hunting field, such as natural post and rail, (all post and rail fences should have at least 2 rails plus a ground rail) brush, stone wall, white board fence, or gate, chicken coop, aiken, hedge, oxe, etc. Oxers are not to be square. (In situations where the only rails available are colored, they will be allowed). A ground line is recommended for all fences. Management may set up any course they feel is a fair test of a hunter; however, the course must be set up with at least 24 feet between fences in the same line.

36, 48, 60 or 72 feet is preferable. All lines must be set at distances measured by a tape measure. Lines must be divisible by 12'. All turns must be curved, giving the horse ample room to get a straight line to the next fence. Broken lines are allowed. Horses/ponies must be allowed at least 3 straight strides before each fence. The course may include an In and Out combination and should have 2 changes of direction. Judges are responsible for correctness of each course after it is set and shall call the show committee's attention to any errors that would tend to result in unfair or inappropriate courses. In handy hunter classes, fences shall simulate those found in trappy hunt country; the course must have at least two changes of direction and at least one combination; horses are required to trot over one fence toward the end of the course.

b. A chicken coop hinged at the top and free at the bottom and jumps such as the triple bar and hogs back, targets and any spread over 4' are prohibited.

c. The suggested distance for an in and out when used in a ring is 24'-26' and an outside course 26'-28'. It must be measured by a tape measure. An in and out is considered as two obstacles in the required number of fences, but must never be used as a first fence.

d. The top element of all fences must be securely placed so that a slight rub will not cause a knock down and must be equally secure for different heights in the same class.

e. Except in cases of inclement weather, broken equipment or similar emergency, a course shall not be altered except by decision of the show committee. If one or more original fences are rendered unusable during a class and no duplicate exists, the show committee may substitute fences which approximate as nearly as possible the originals.

f. Clear descriptions, including heights of fences of all courses should be set forth in the prize list except for handy classes which may be withheld until time of class. If courses are not illustrated in the prize list, they must be posted at least one hour before scheduled time of class. The plan or diagram of the course must show the obstacles which must be taken in the order indicated by numbers; but apart from this, the rider is not required to follow a compulsory track. An arrow is used to indicate the direction in which each obstacle is to be taken.

B. Tack: refer to Equipment/Tack Section of Rule Book.

C. Classes: Shows may have classes for maiden, novice, limit, conformation, 1st and 2nd year hunter, low and regular working hunters. Classes may be further divided into Jr. and Sr. Exhibitor.

D. Soundness: All horses/ponies must be serviceably sound. Quality, substance and soundness. Judges must penalize, but not necessarily eliminate horses with structural faults, defects and blemishes (such as pin firing) in areas which may impair their activity and durability

E. Performance

1. An even hunting pace, manners, jumping style, together with faults and moving over the course as well as when being jogged for soundness. When the class is held in a ring, the performance starts as the horse enters and ends when he leaves. When the class is held outside, the performance starts at any spot designated by the show committee, and ends at any spot so designated. If the start and finish are not clearly set forth, it is suggested that a judge consider the start approximately 50' before the first obstacle and the finish approximately 50' after the last. Markers should be used.

2. In hunter classes over fences, horses/ponies shall not be required to show at a walk, trot and canter or to re-jump the course, unless eliminations are held. If eliminations are held, the finals shall be judged as an independent class.

3. In case of broken equipment, the rider may either continue without penalty or stop and correct the difficulty, in which case he will be penalized 3 faults, which will be non-cumulative. In case of loss of a shoe, rider may continue without penalty or be eliminated, at the discretion of the rider.

F. Scoring of hunters

1 Faults

a. When a horse/pony makes 2 faults at one obstacle, only the major fault will be counted, except refusals, which will count in addition.

b. When an obstacle is composed of several elements in the same vertical plane, a fault at the top element is the only one penalized.

c. When an obstacle requires two or more fences (in and out), the faults committed at each obstacle are considered separately, in case of a refusal or run out at one element, entry must resume the previous as well as the following elements.

d. Judges shall penalize unsafe jumping and bad form over fences, whether touched or untouched.

2 Touches

a. Light touches are not considered, but may be scored according to scale below for reference in cases where elimination is difficult.

i. With any part of horse's/pony's body behind the stifle – two (2) faults.

ii. With any part of the horse's body in front of the stifle – one (1) fault.

iii. Of standard or wing in jumping obstacle with any part of horse, rider or equipment – one (1) fault.

iv. Of obstacle by touching a wing or post, it shall be counted as a knock down of obstacle with knock down penalties as described below.

3 Knock downs An obstacle is considered knocked down when its height is lowered by a horse or rider.

a. With any part of the horse/pony's body behind the stifle – 4 faults.

b. With any part of the horses/pony's body in front of the stifle - 8 faults.

- c. Of standard or wing in jumping obstacle with any part of the horse, rider or equipment - 8 faults.
- d. Placing any foot in Liverpool, ditch or water - 8 faults.
- e. Hind knock downs - not the fault of bad jumping, shall not necessarily eliminate a horse/pony from an award, but should be scored against in a comparative manner.
- f. When a horse/pony touches an obstacle, causing a rail of an adjoining panel or wing to fall, it shall not be construed as a knock down.

4. Disobedience Circling once upon entering the ring and once upon leaving the ring is permitted

- a. 1st refusal, run out, bolting on course, extra circle or showing an obstacle to a horse/pony - 8 faults
 - b. 2nd refusal, run out, bolting on course, extra circle or showing an obstacle to a horse/pony - 8 faults
 - c. 3rd refusal, run out, bolting on course, extra circle or showing an obstacle to a horse/pony - elimination. *No courtesy jump after elimination.*
 - d. Jumping an obstacle before it is reset elimination.
 - e. Bolting from ring - elimination.
 - f. Failure to keep proper course - elimination.
 - g. Jumping an obstacle not included in course - elimination.
5. Falls: Horse/pony and/or rider falling in competition - elimination.
6. Maiden, novice, limit horses: Open to horses/pony which have not won a blue ribbon, three blue ribbons, or six blue ribbons respectively

XIII. HUNTER PONY DIVISION

A. Pony hunters: Regular classes are open to all ponies 14.2 hands and under whose qualifications shall follow as nearly as possible those outlined for hunters. Fences are not to exceed 3'

B. Courses: Same as for hunters, except that the suggested distance for in-and-out for small ponies not exceeding 12.2 hands - 20', for medium ponies over 12.2 and not exceeding 13.2 hands - 22', and for large ponies over 13.2 hands and under 14.1 hands - 24'. The first fence in a pony hunter course must be a vertical fence (brush or rail). Oxers and coops are prohibited as a first fence.

C. Scoring Same as for hunters.

D. Division of classes: Classes for pony hunters may be divided by size of pony. Manners and suitability of a pony for the rider shall be emphasized in all classes. Extreme speed shall be penalized. Suitability of a pony for a rider shall be determined by height and weight of the rider as related to the size of the pony as well as the compatibility of the rider and pony.

XIV. LITE SHOD TENNESSEE WALKING HORSE/PONY SHOW RULES

A. Lite Shod Walking Horse/Pony Tack and Attire

1. For Attire and Tack requirements (by seat), refer to Attire Section and Equipment/Tack Section of /Rule Book.

B. The Lite Shod Shoe is defined as follows:

The Lite Shod Shoe must not exceed 3/4 inch in width by 3/8 inch in thickness, except for the caulk which must be no thicker or wider than 3/4 inch. The caulk must not exceed a 1 inch turnback and the shoe must not extend more than 1/4 inch beyond the hoof at the toe, with no bare plate or other weight inside the shoe. Borium not exceeding 1/8 inch in thickness will be permitted on the caulks of the shoe. Maximum thickness of the shoe and caulk with borium must not exceed 7/8 inch. The heel of the shoe must not extend beyond the bulb of the heel when a perpendicular line is drawn from the bulb of the heel to the ground. No shoe on any foot may exceed these dimensions. Keg shod or barefoot horses may compete.

C. Classes

1. LITE SHOD PLANTATION IN HAND

Horses/ponies to be judged on conformation and way of going. Bridle or show halter allowed. Judge should observe horses in the parked position, flat walk and running walk.

Lite Shod Pleasure Classes: The Lite Shod Pleasure Horse/pony should perform the true walking gaits in a relaxed fashion with an alert and willing attitude. The Lite-Shoe Horse should display pleasure qualities necessary for road and responsiveness, manage-ability on a light rein, etc. He must stand quietly and back readily on command.

2A. LITE SHOD PLEASURE HORSE/PONY (2 GAIT) The plantation pleasure horse/pony should display brilliance and show presence while performing true walking gaits. Form is not to be sacrificed for speed. The horse is to be well mannered and manageable on a light rein. Manners are paramount for a pleasure horse/pony and should be given serious consideration in judging. The horse should be well balanced, both front and rear. He must back readily. Appropriate English or Western tack and attire are permitted.

2B. LITE SHOD PLEASURE HORSE (3 GAIT)

Horses to enter the ring at a running walk. To be shown at the flat walk, running walk and canter, both ways of the ring. A noticeable increase in speed between the flat walk and the running walk is required. Backing is also required. Horses/ponies must stand quietly in the line up. Appropriate English or Western tack and attire are permitted.

3. LITE SHOD EQUITATION

Same as the Lite Shod Pleasure except the rider is judged. Individual workouts are permitted at the judge's discretion.

4. JUNIOR LITE SHOD PLEASURE (2 GAIT)

Same as Lite Shod All Day Pleasure (2 Gait) except only riders 17 years of age and under may enter. Age to be determined by NYSSHA age group rules.

5. JUNIOR LITE SHOD EQUITATION (2 GAIT)

Same as Junior Lite Shod Plantation Pleasure (2 Gait) except the rider is judged.

6.

LITE SHOD TRAIL PLEASURE (2 or 3 GAIT)Horses/ponies in Trail Pleasure classes are using horses/ponies that are appropriate for use on **groomed trails or bridle paths.** Trail Pleasure horses/ponies perform true walking gaits with an effortlessness geared toward encouraging longevity and stamina. Trail Pleasure classes are judged on the ability of the horse/pony to provide a safe pleasurable ride while performing authentic walking gaits. A halt, back and/or side pass (one or both ways of the ring at the judge's discretion) may also be asked for. Horse/pony must be extremely responsive, quiet and well mannered, displaying the qualities that are necessary for road and trail riding. Horse/pony must be manageable on a light rein at all times, stand quietly when asked and back readily. This class does not include obstacles.

7. LITE SHOD WORKING TRAIL PLEASURE

Working Trail Pleasure horses/ponies are suitable to be taken directly from the show ring and put to work in a trail environment where a variety of terrain and conditions are encountered. Due to the variety of terrain and possible obstacles encountered on the trail, Working Trail Pleasure horses/ponies may have shorter strides. The Working Trail Pleasure horse/pony demonstrates true walking horse gaits in an economical manner. All movement is forward movement, with gaits tending toward the “using gaits” rather than the “showy gaits.” Recommend placement of cones, cavalletti or other small obstacles to be worked before lineup.

8. LITE SHOD COUNTRY PLEASURE

Country Pleasure Classes may be breed specific or Open Gaited Breed. Country Pleasure classes may be two or three gait. The intermediate gait is the choice of the exhibitor, but the intermediate gait may not be the canter, lope or hand gallop. The ideal country pleasure horse/pony should reflect the name of the division. This should be the type of horse/pony that you would willingly ride if you were to go out to spend a day in the country. In Country Pleasure classes, correctness of gait is not evaluated. The horse/pony has the ability and the fitness level to travel all day over a variety of terrain. The horse/pony displays exceptional manners, the horse/pony exhibits an alert and willing attitude, the horse/pony and rider are in tune with each other, the horse is pleasant, confident and obedient, the horse/pony has a quiet nature but is responsive to the rider's commands, the gait is a smooth and comfortable “saddle gait” the horse/pony is calm, horses line up and stand quietly before being asked to back.

9. LITE SHOD WESTERN PLEASURE (2 GAIT or 3 GAIT)

Entry shall reflect suitability of the WH as a western working horse, exhibiting qualities suitable for ranch work. The western pleasure horse/pony works quietly exhibiting an exceptionally smooth, comfortable ride without excessive action or animation. A good western pleasure horse/pony should have a balanced flowing motion with a free and easy gait. The horse/pony should be ridden on a loose rein, and should exhibit a true, four beat walking gait with a cadenced head motion (nod). The head set should be natural, neither excessively nosed out or over flexed at the poll. The head should not be high but should exhibit the type of head carriage of WH used as a western working. It is recommended the judge ask the entries to back clear of the line-up and do a 360-degree neck reined turn, either right or the left, rider's discretion. A 360 is required in all western championship classes. If a western horse/pony has a fast, uncontrollable lope or requires pumping or bumping, he must be penalized.

10. LITE SHOD ENGLISH PLEASURE (2 GAIT OR 3 GAIT)

Horses in English Pleasure classes are natural English pleasure show horses/ponies, executing authentic walking horse gaits fashionably and freely in a forward-moving manner exhibiting pleasure horse/pony qualities. There is no wasted motion – all effort is used for forward motion. The horse/pony is well balanced, the shoulders roll and reach, head nod is prominent, overstride is easily observable (may be considerable) and all gaits are smooth. High front-end elevation and animated full body motion are not required elements.

11. LITE SHOD WALKER COMMAND (2 GAIT OR 3 GAIT)

To be judged on the ability of the horse/pony and rider to obey immediately the commands given by the judge at any gait. Failure to follow command is elimination. To follow General Command class rules of NYSSHA.

12. LITE SHOD TRAIL CLASS

The Trail Class may contain any obstacles as may be setup by the show. To follow general Trail Class rules of NYSSHA.

13. LITE SHOD PLEASURE STAKE

To be shown at a flat walk, running walk and canter. A noticeable increase in speed between the flat walk and running walk is required. To be judged as a pleasant riding horse/pony with true road and trail qualities, manners, substance, performance and conformation to be considered. A pattern may be required. Type of pattern to be determined by the judge.

14. LITE SHOD MINT JULEP

Glasses are filled to overflowing with clear or colored liquid. Riders are handed a glass and take the rail at a flat walk. This is a 2 Gait class with horses performing the flat walk and running walk both ways of the ring. A noticeable increase in

speed between the flat walk and running walk is required. Contestants must remain seated in the saddle, standing in the stirrups/irons is reason for disqualification. Contestants are called in and each glass is to be measured with a ruler on a level surface. Measurements are recorded for the appropriate entry #. Placings are made on the basis from the most to the least liquid remaining. In the event of one or more ties, those riders will take the rail with the remaining liquid and the canter is called for. Riders are called back in and remaining liquid is measured again with a ruler on a level surface.

15. LITE SHOD INDIVIDUAL PERFORMANCE CLASS

Riders will design a routine to be performed individually to the music they have chosen. Several walking gaits and other movements should be utilized both ways of the ring to create a pleasing picture. Presentation should be 2 to 3 minutes long. Exhibitor must execute two circles at the running walk and two circles at the canter with a lead change in each direction. Exhibitor must back. All other elements of the routine are at the rider's discretion.

16. LITE SHOD PLEASURE DRIVING

To be shown in a two-wheeled cart both ways of the ring at a flat walk and a running walk. Horses/ponies must stand quietly and back readily. Performance of the horse shall be uppermost and in no way overshadowed by equipment or turnout. Pleasure horse/pony's qualities are paramount. Headers are optional when horses/ponies line up.

XV. PONY DIVISION

A) General Rules

1. There shall be no age limit for riders in pony specified classes. There shall be no age limit for riders in pony specified classes.
2. Pony classes shall be governed by the same class rules for horses.
3. Equines 38" and under must show as a miniature horse or as a pony. They may not cross enter with the pony division.

B) Class Descriptions

1.PONY PLEASURE: Open to all seats unless otherwise specified. To be shown both ways of the ring at a walk, trot/jog and canter/lope. Judged on manners, performance, quality and suitability to purpose. Loose rein upon command. Shall stand quietly and may be asked to back. Performance 80%, conformation 20%.

2. PONY COMMAND: To follow the same rules as Horses
See Sec. VI. Misc. 1

3. **PONY ROAD HACK:** Entries will be asked to walk, trot/jog, extended trot/jog and canter/lope both ways of the ring. Ponies are required to hand gallop one way of the ring. Only 8 ponies may hand gallop at one time. May be asked to back. To be judged on performance, substance and manners. Performance 80%; conformation 20%.

4. **PONY EQUITATION:** Open to all seats.

5. PONY PURSUIT: Pylons are placed at four corners of the ring, approximately 15 feet from the rail (or more according to the number of entries and size of the ring), allowing adequate room for several ponies to safely move side by side between the cones and the rail. Ponies will space out evenly around the rail. When the class begins, ponies will trot/jog. Cantering or otherwise breaking gait will result in elimination. Any pony that tips over a cone, cuts inside a cone or is passed on the outside by another pony must come in to the center. Placing are determined by the reverse order of their elimination. The last remaining pony on the rail is the winner. If two or more ponies remain and none seem to be gaining on the other(s) after a reasonable amount of time has passed, the judge will stop the class and call for a run off. At the judge's discretion, ponies can be asked to race (at the trot/jog) to one end of the ring only or down and back to the original starting point. Order of finish will determine placing. Except for as noted above, at no time will the class be stopped or reversed. Any exhibitor not allowing another pony to pass will be disqualified.

6. PONY PLEASURE DRIVING

Pony Driving split into two divisions: 11.2 hands and under AND over 11.2 hands. Divisions may be shown together.

7. PONY 11.2 AND UNDER IN HAND PERFORMANCE

A. Obstacle In-Hand Classes:

1. Class to be judged on performance and way of going with emphasis on manners throughout the course. Entries will be evaluated on responsiveness and willingness, plus general attitude.
2. Ponies must be 3 years or older to show in Obstacle In-Hand classes.
3. Any baiting in such class is a disqualification
4. Obstacle Guidelines: Ingenuity and originality in adapting and combining various obstacles are encouraged. However, all obstacles should be safe for exhibitors as well as horses. Suggested obstacles include:
 - a. Back through or out of obstacle
 - b. Walk through water or simulated water
 - c. Put on and remove equipment from person or horse
 - d. Walk through a narrow passage
 - e. Pick up an object and place it in a designated location
 - f. Walk across a bridge or simulated bridge
 - g. Walk pattern created with poles, pylons, (figure 8, pentine, cloverleaf, etc.
 - h. Ground tie pony in a circle
 - i. Side-pass
5. Pony to be shown in a halter with lead. Pony may not be touched by the exhibitor unless the judge or course designer instructs or if side passing is required. Whips or crops are prohibited. Tying up of long tails is permissible.

6. Judge/Course Designer to walk the course with exhibitors (without pony) prior to judging.

B. Obstacle Ground Driving Classes:

1. Class to be judged on performance and way of going with emphasis on manners throughout the course. Entries will be evaluated on responsiveness and willingness, plus general attitude.
2. Pony to be 2 years old or older to show in Obstacle Ground Driving.
3. Obstacle Guidelines as in Obstacle/Trail In Hand Classes.
4. **Tack: refer to Equipment/Tack Section of Rule Book.**
5. A pony entered in ground driving class may not cross-enter with any driving class.

C. Pony 11.2 and Under Hunter or Jumper Classes:

1. General Rules:
 - a. There will be a minimum of 16' between jumps except for an in and out which should be set at approximately 12' apart.
 - b. Fences to be constructed of light-weight materials which can be easily knocked down, i.e. PVC piping, wooden posts no greater than 2 inches in diameter, etc. Jumps must be a minimum of 5 feet wide, and uprights a maximum of 48" in height. A ground pole must be used for any rail jump.
 - c. Ponies must be 3 years old or older to participate in any over fence class.

D. Pony 11.2 and Under Hunters:

1. Judged on style, manners and way of going with preference given to those ponies that cover the course at an even pace, with free-flowing strides, as in a brisk trot or canter, but must maintain same gait throughout the course. Circling once upon entering the ring and once upon leaving the ring is permissible. Hunter must demonstrate at least one, but no more than four changes of direction. Charging fences, or not maintaining the same gait throughout the entire course shall be penalized.
2. Jumps must be a minimum height of 18" and a maximum of 24". Ground poles are required. There will be a minimum of 4 obstacles, and horses are to make a minimum of 6 jumps and a maximum of 8 jumps.
3. Major faults to be considered are: knockdowns, touched, refusals, bucking or kicking, spooking or shying, showing obstacle to the pony or wringing the tail.
4. Causes for elimination: 3 refusals, off course, crossing your own path, fall of pony/exhibitor, jumping of obstacle by exhibitor, carrying of whip, unsound pony.
5. The type of exhibitor footwear may include any athletic type shoe.

E. Pony 11.2 and Under Jumpers:

1. To be scored mathematically, based on faults incurred between the starting line and the finishing line. Circling once upon entering and once upon leaving the ring is permissible, but not after crossing the starting line.
2. Minimum height for jumps must be 18", maximum height 28".
3. Exhibitor may not go over the jumps with the pony. Whips are permitted, and the exhibitor's type of footwear may include any athletic type shoe. Front leg wraps and/or boots are optional.
4. Jump-offs are to occur for the first place between ponies that tied for first place only. The jump-off will be held over the original course. The number and location of the jumps are to remain the same as well as the path of the course to be taken. Final determination is the combination of least faults and fastest time of the jump-off.
5. Scoring: knockdown 4 faults, refusal 3 faults, circling after crossing starting line 3 faults, crossing own path 3 faults.
6. Causes for elimination: 3 refusals, off course, fall of exhibitor/pony, jumping of jump by exhibitor, failure to pass through the start and/or finish cones or knocking such cones over.

XVI: GYMKHANA DIVISION

AGE GROUPS:

Please note: No cross entering within age groups.

Leadline - ages 3-8 years old:

- Halter & Bridle Is Required.
- Lead must be attached to halter.
- Must be led by someone 14 years old or older.
- Spotter is required for exhibitors 3-4 years old.
- No cantering allowed.

Pee Wee - ages 5-10 years old:

- No Lead Attached

Walk/Trot – all ages

Junior Exhibitor - 17 years old & under

Senior Exhibitor - 18 years old & over

Jack Benny - 39 years old & over

Attire: refer to Attire Section of Rule Book.

Tack: refer to Equipment/Tack Section of Rule Book.

- Host club shall designate the order of competition according to the entries.
 - In team events, a horse or pony may not be used more than twice.
 - In a single class, a horse or pony may compete only once. In Leadline, PeeWee and Walk/Trot classes horses or ponies may be used no more than twice.
 - Feet do not have to remain in the stirrups.
 - Off-course shall be an automatic disqualification.
 - Unnecessary interference between entries shall cause disqualification.
 - Entrant interfered with shall be entitled to a rerun.
 - No pattern shall be changed during the course of an event.
 - All courses shall have a timing starting, and finishing line.
 - All events shall have two timers per horse or pony or an electric timer. Timers will signal rider to start.
 - Starting before timer's signal, failure to start after timer's signal could cause disqualification. Time will be when horse or pony's nose crosses the finish line.
- Cruelty to, or abuse of a horse by any person at a recognized show is forbidden. The judge and/or show management has the authority to dismiss from the class or show grounds, any person for cruelty to, or abuse of a horse. If a rider is disqualified from showing by the management, or by officials, or if a horse is entered and not shown, the entry fee will not be refunded. Evidence of bleeding, either from the mouth or other areas of the horse shall be cause for elimination of that horse from that class. Showing a horse with raw or bleeding sores around the coronet, pasterns or legs is prohibited.
- If a Mystery Class is offered, pattern will be chosen from any of the following:

FLAG RACE

Plastic buckets filled with sand will be used. Contestants will be timed when he or she crosses starting line. Contestant shall pick up flag from first bucket and place flag in second bucket on opposite side of the ring. Contestant will be given time when nose of horse or pony crosses starting line and finish line. Not placing flag in second bucket, disqualification.

SIT A BUCK

Upon entering the ring bareback contestant receives a simulated buck, which is shall be placed on the left side under the buttock. One-half of the buck must be showing at all times. Loss of buck, contestant shall proceed to the center of the ring. No chaps shall be worn. Contestants shall follow the commands of the ring master.

DASH RACE

Contestants shall ride horse or pony down to and around the barrel at the end of arena and back to start/finish line. This is a timed event. Knock down of barrel is a disqualification.

BARREL RACE

Three barrels shall be place in a cloverleaf pattern. Distance between end barrel and timing line, 85' – side barrel, 20 feet. Entry shall cross timing line, circle right hand barrel to the right, circle left hand barrel to the left, circle end barrel to the left and cross timing line. Disqualification if barrel is knocked down. Contestant may elect to take either barrel he chooses first.

SPEAR THE RING

This is a timed event. Time starts when the exhibitor crosses the starting line. Exhibitor will be given a spear. Exhibitors spear the ring that is suspended from a pole on each side of the arena. Exhibitors will be given time when nose of horse or pony crosses starting line and finish line.

STAKES RACE

This is a timed event. Five stakes shall be set up 21 feet apart in a straight line. First stake being 21 feet from the timing line. Rider shall have his choice of side on which to pass first stake, but once first stake is taken, horse/pony must bend between stakes, circling fifth stake and returning through course in the same manner. A knocking down of a stake shall be disqualification. No penalty shall be assessed for bumping or touching a stake without knocking it down. Touching a stake with hands is disqualification.

KEYHOLE RACE

This course shall be laid out with a marked keyhole on the ground with the throat of the keyhole (marked by cones) perpendicular to and facing the timing line at the center of the circle of the keyhole, about 100 feet from the timing line. The keyhole shall be in the form of a marked circle 20' in diameter with a throat 4' wide and 10' long. The horse/pony shall cross the time line and enter the circle of the keyhole, turn around in either direction entirely within the circle of the keyhole and cross the timing line. The entrant is disqualified if the horse/pony steps on or over the marked keyhole at any point, or if the horse/pony turns around in the throat of the keyhole rather than the circle of the keyhole.

Samples of Keyhole Patterns:

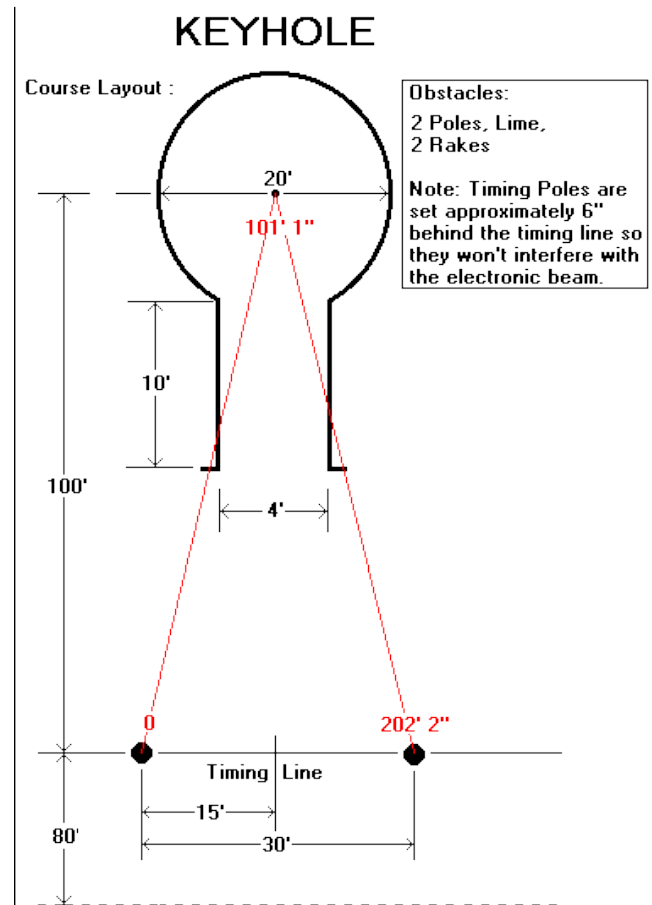
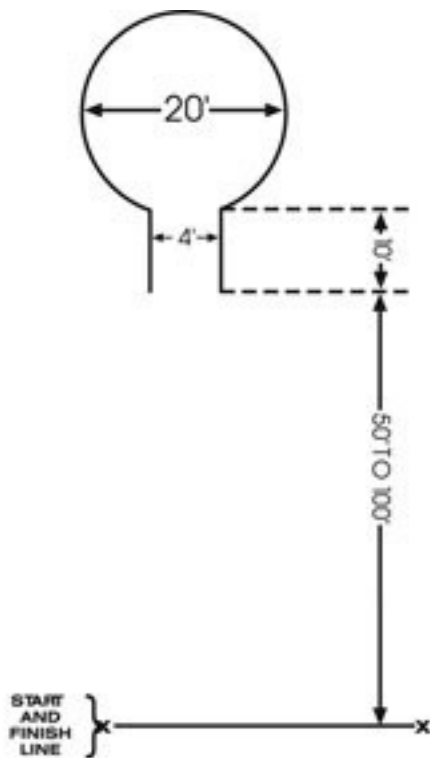

MUSICAL CHAIRS

Sacks shall be arranged in form of a circle and spaced evenly. There shall be one or more sacks less than entrants. When music begins, hors/pony shall lope counter-clockwise around circle outside sacks. When music stops, each rider must dismount and lead horse forward to the nearest vacant sack, holding reins in his hand. The persons not finding sacks shall be eliminated, one or more sacks shall be removed and remaining riders shall remount and continue around circle while music plays. This procedure shall continue until all but two entries are eliminated. Then two sacks shall be place at the ends for foul lines. The two riders ride around sacks in parallel lines until music stops. Then riders shall dismount, touch the rail and lead horse/pony to the sacks in the center of the ring. First rider properly reaching sack in center of the ring shall be declared the winner. Split reins are optional and reins over the horse's head are optional.

Any of the following offenses shall disqualify an entry:

1. Breaking gait
2. Passing horse on the inside
3. Turning back after passing a sack
4. Cutting across circle inside sacks

The person controlling the music must be located where he cannot see activities in the ring. No kickers shall be allowed in this event.

JUNIOR MUSICAL CHAIRS

Same as Musical Chairs except the gait shall be trot/jog and riders shall not dismount.

TWISTER RACE

To be run either way of the ring. Poles and barrels to be set even and in line, to be safe distance from ring sides.

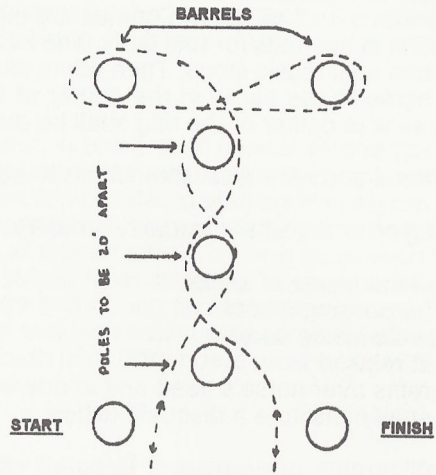

POLE BENDING PATTERN

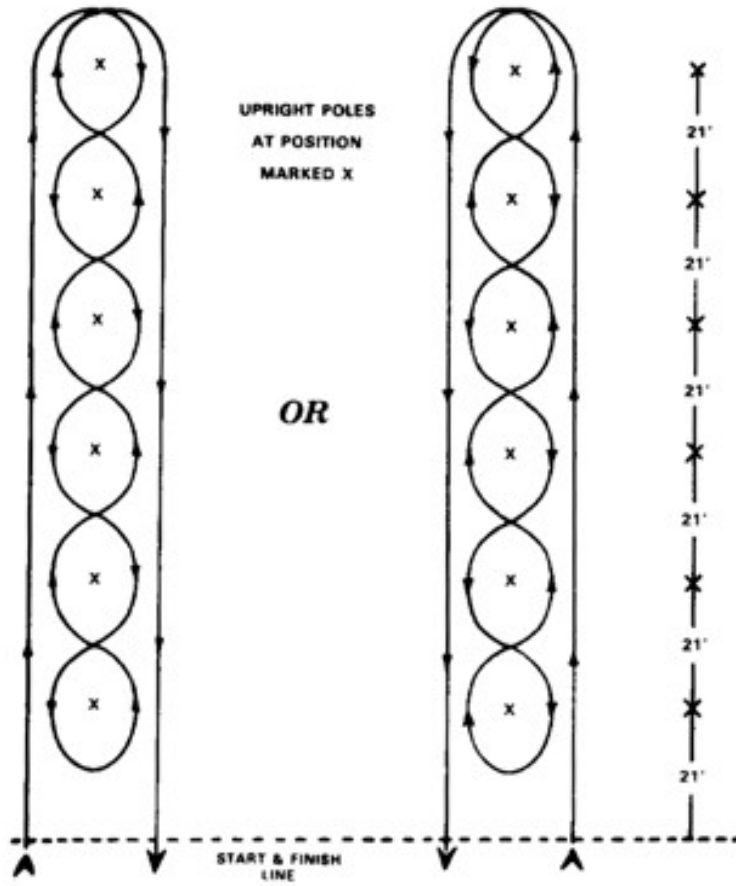

STRAIGHT BARRELS

This is a timed event. Three barrels are set in a row. Equines may either turn to the left going down, turning the end barrel to the left, then turn barrels to the right on the return trip: OR equines may turn barrels to the right going down, turning end barrel to the right, then turn barrels to the left on the return trip. Course shall measure 37 feet from starting line to first barrel, and 50 feet between the next two barrels. The end barrel should be at least 20 feet from the end of the arena wall/fence.

Pattern may be started from the right or the left. Disqualification results for the equine turning the barrel wrong way, or rider holding up barrel with hand. Knockdown of barrel is five (5) second penalty per barrel.

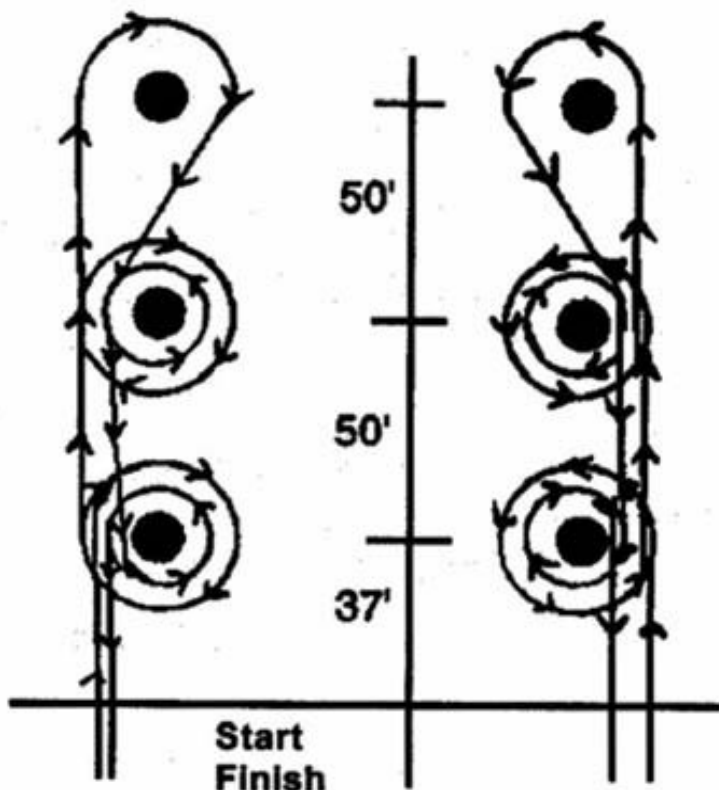

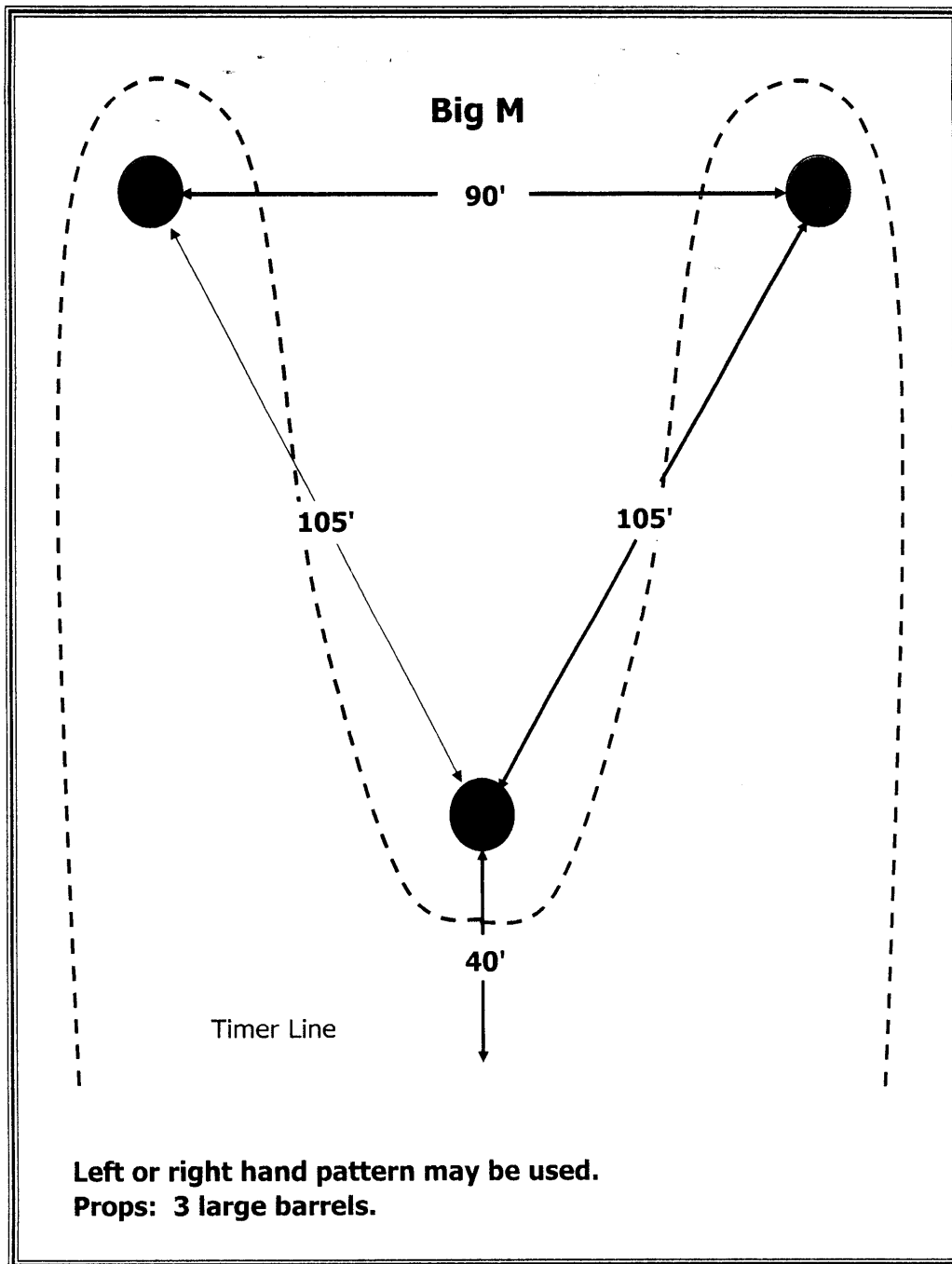

QUADRANGLE BARREL RACE

COURSE: Four barrels and a pylon shall be placed in a formation according to the diagram below.

EVENT: Rider may start with either two left turns followed by two right turns or two right turns followed by two left turns, starting with the two barrels farthest from the start/finish line. Then the rider must proceed around the pylon in either direction before crossing the finish line, by one of the following options:

Δ = Pylon

Option 1 Option 2 Option 3 Option 4

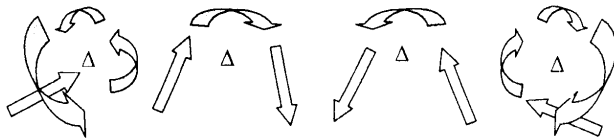

RULES: Penalties -
 a) five-second penalty for each barrel or pylon knocked over.
 b) five-second penalty for using hand, arm, or leg to steady or right a fallen barrel.

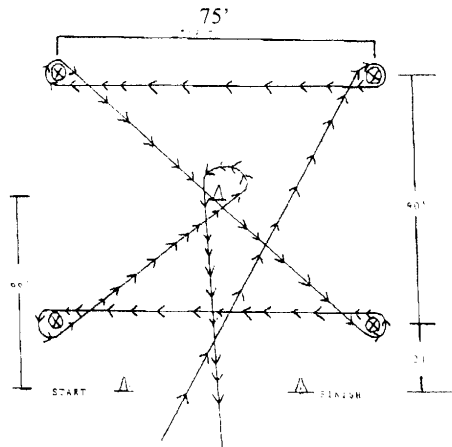

$\frac{1}{4}$ = barrel; Δ = pylon

Speed Barrels

Go through timing line, pass first barrel on either side, pass the succeeding barrels on alternate sides, turn around last barrel, pass remaining barrels on alternate sides, go through timing line.

Course Pattern: Go through the timing poles, pass the first barrel on either side, pass the succeeding barrels on alternate sides, turn around the third barrel, and return in the same manner through the timing line

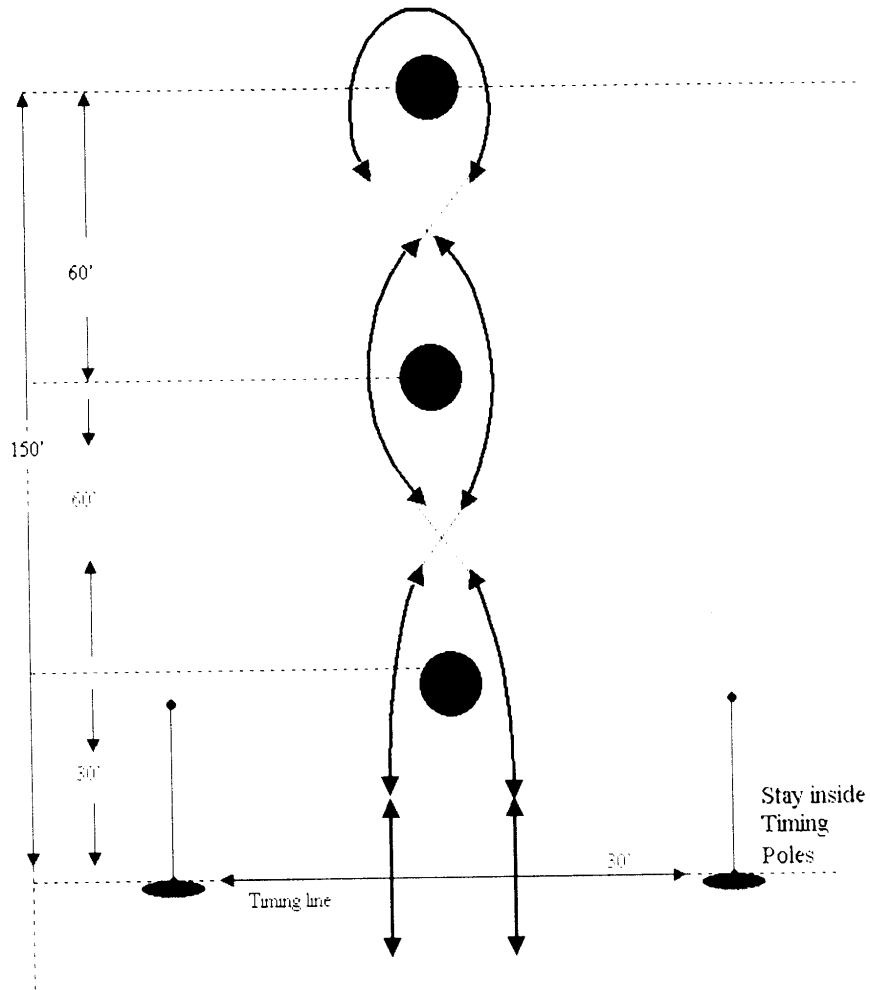

STRAIGHT-LINE BARRELS

COURSE: Five barrels are placed in a straight line, spaced 21' apart, with the first barrel 21' from the start/finish line.

EVENT: Ride to barrel #1 (side optional), weaves in and out to barrel #5, turns barrel #5 and weaves back toward finish line, ending on opposite side of barrel #1 and crosses finish line.

RULES: Penalties -
a) five-second penalty for each barrel knocked over.
b) five-second penalty for using hand, leg or arm to steady or right a fallen barrel.

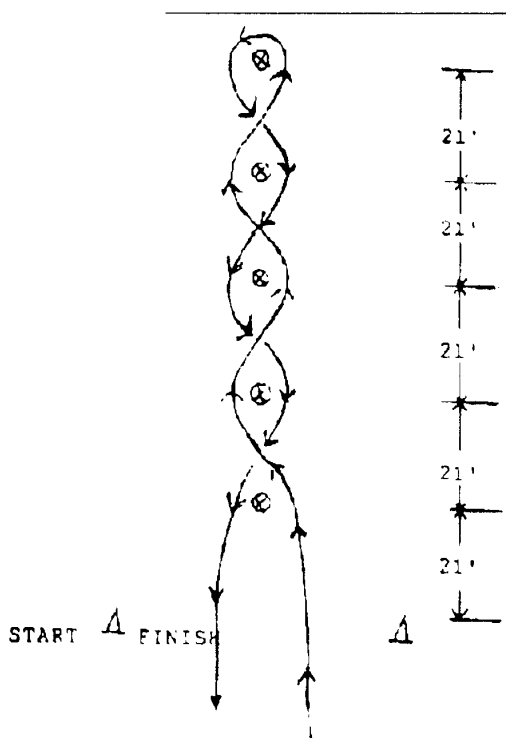

Butterfly

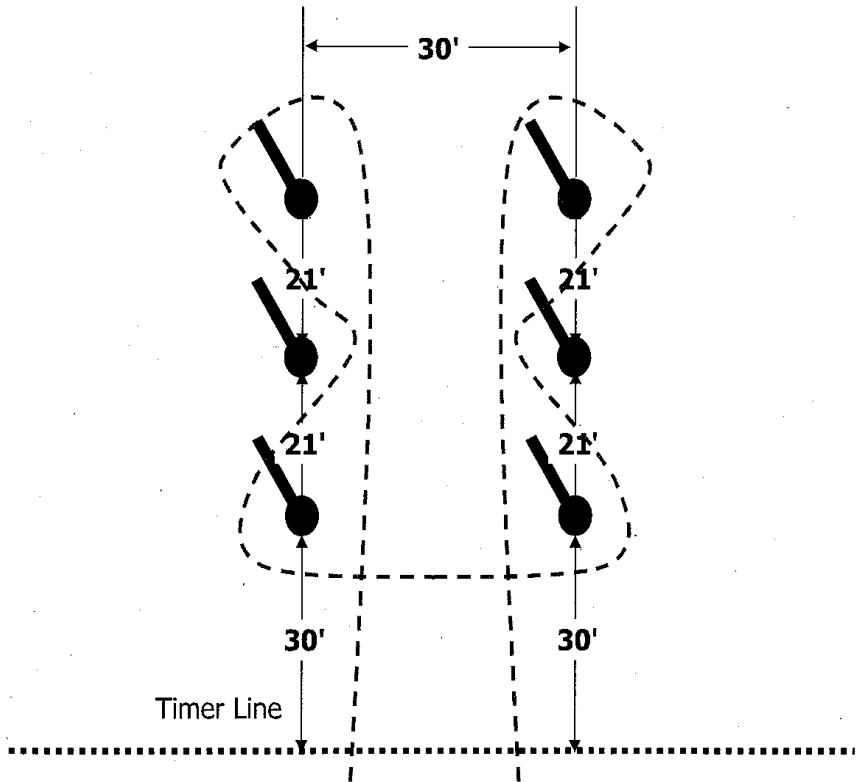

Left or right hand pattern may be used.
Props: 6 standard poles.

Big O

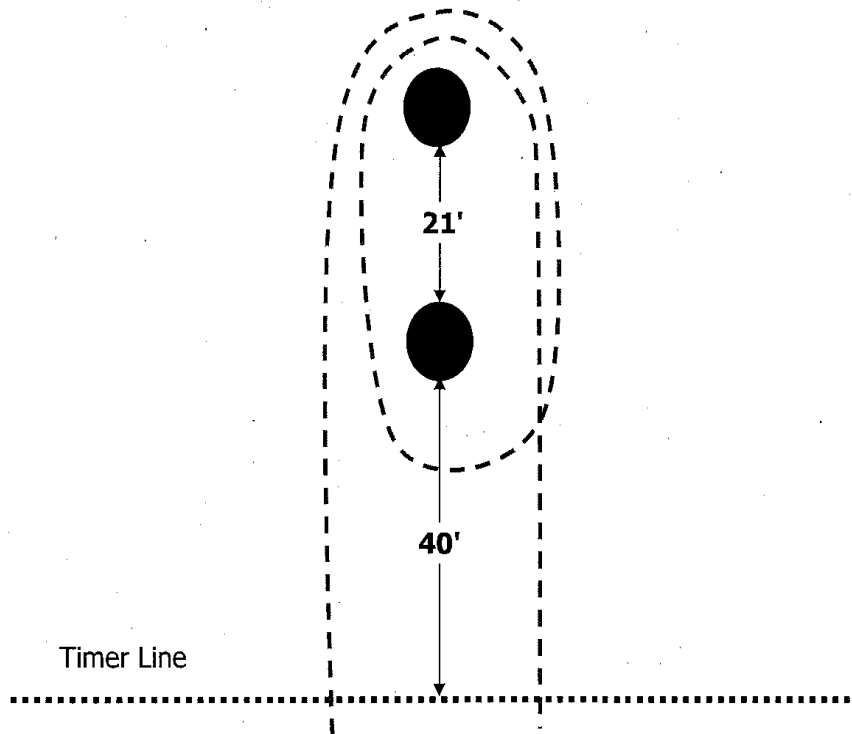

Left or right hand pattern may be used.
Props: 2 large barrels.

Bowtie

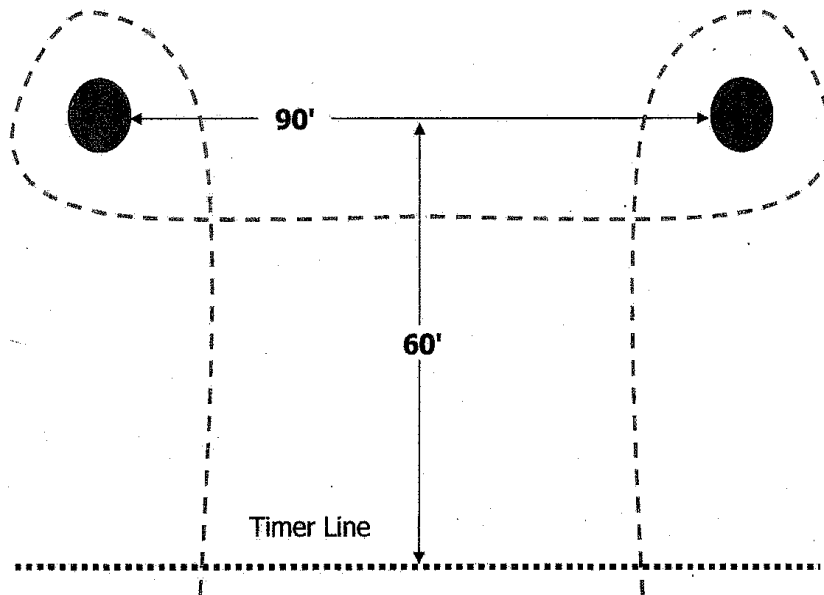

Left or right hand pattern may be used.
Props: 2 large barrels.

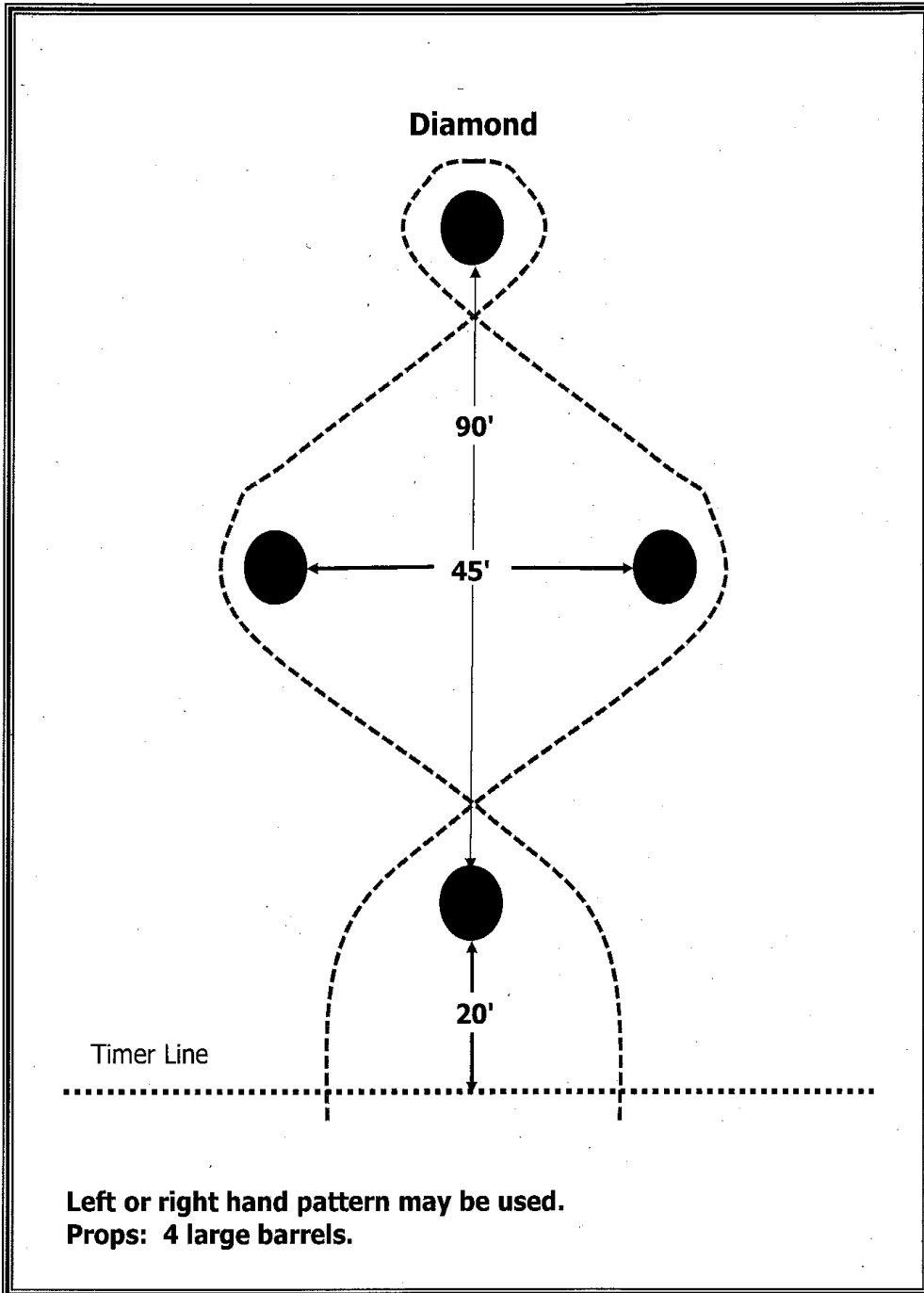

4 Leaf Clover

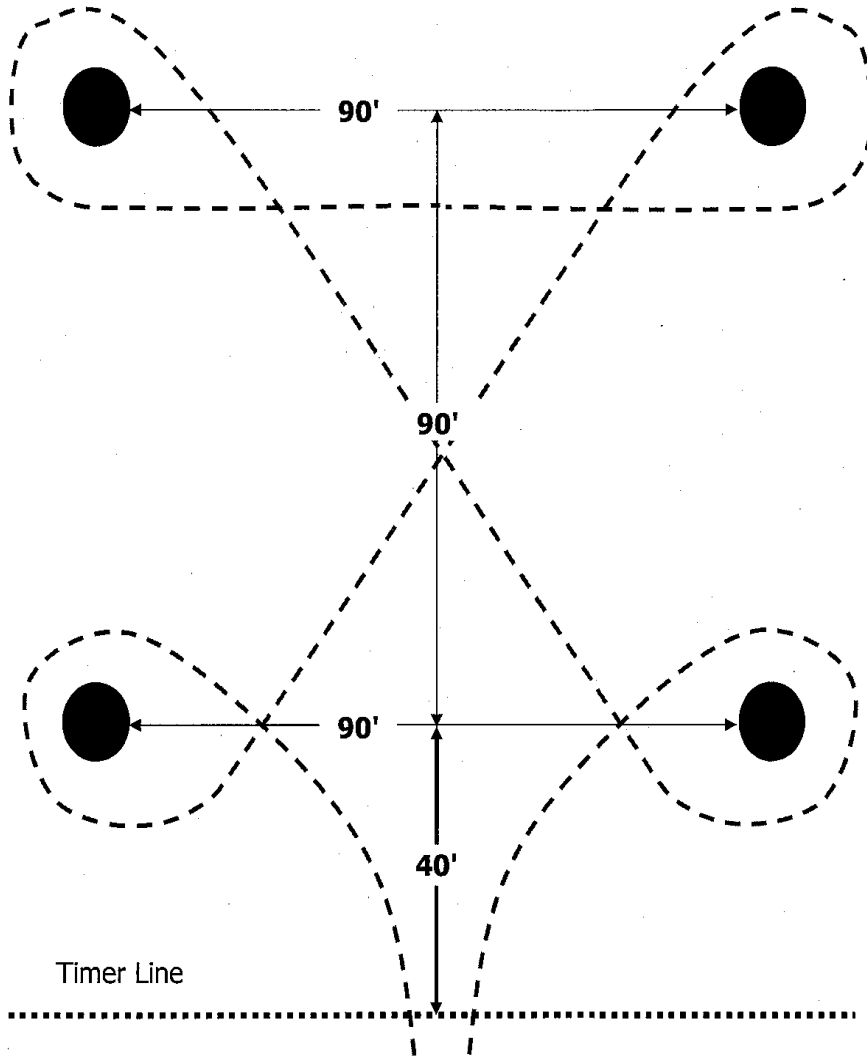

Left or right hand pattern may be used.
Props: 4 large barrels.

Heart Shaped Barrels

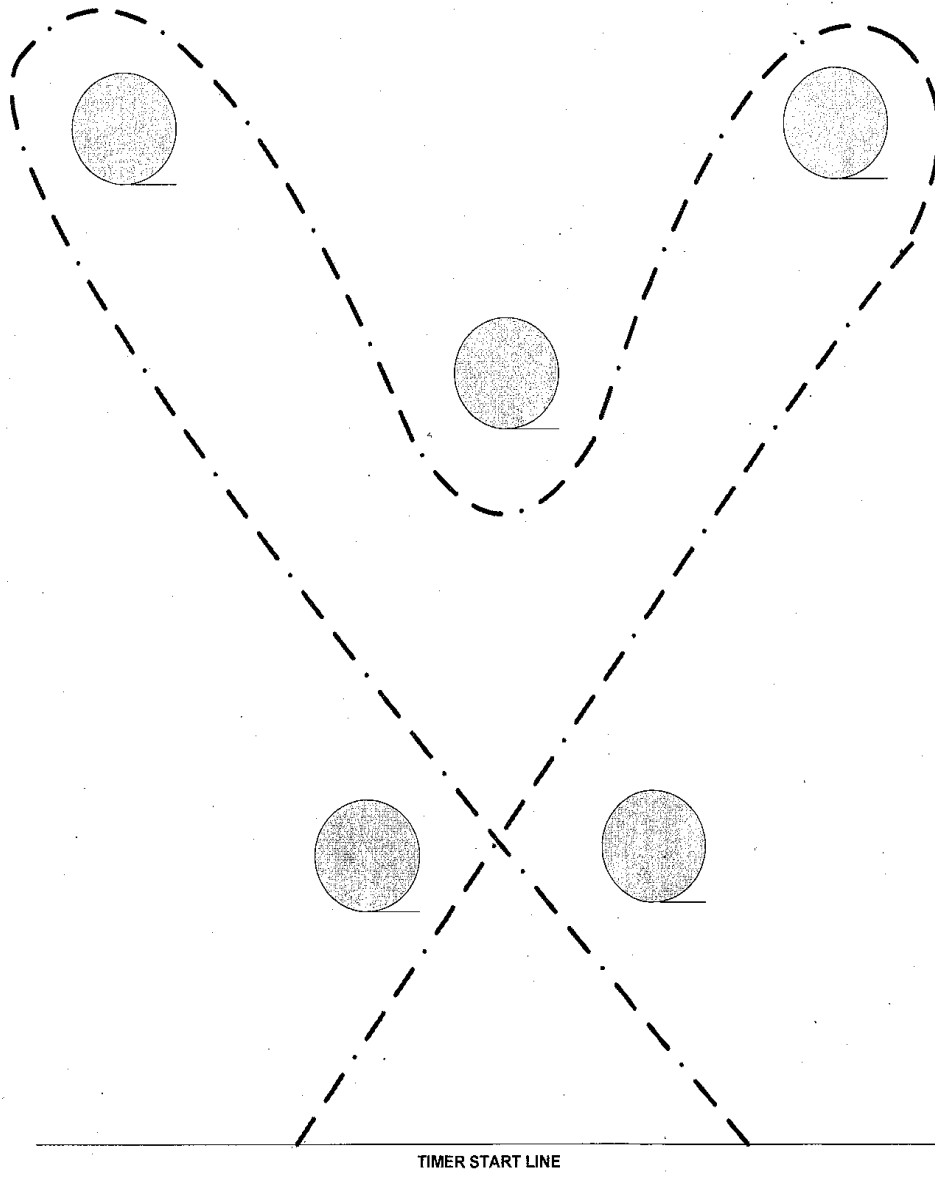

QCGC Copyright 2011

Instructions

Start on either the right or left hand side. 5 barrels are to be used. Measurements are unknown at this time.

HORSESHOE BARRELS

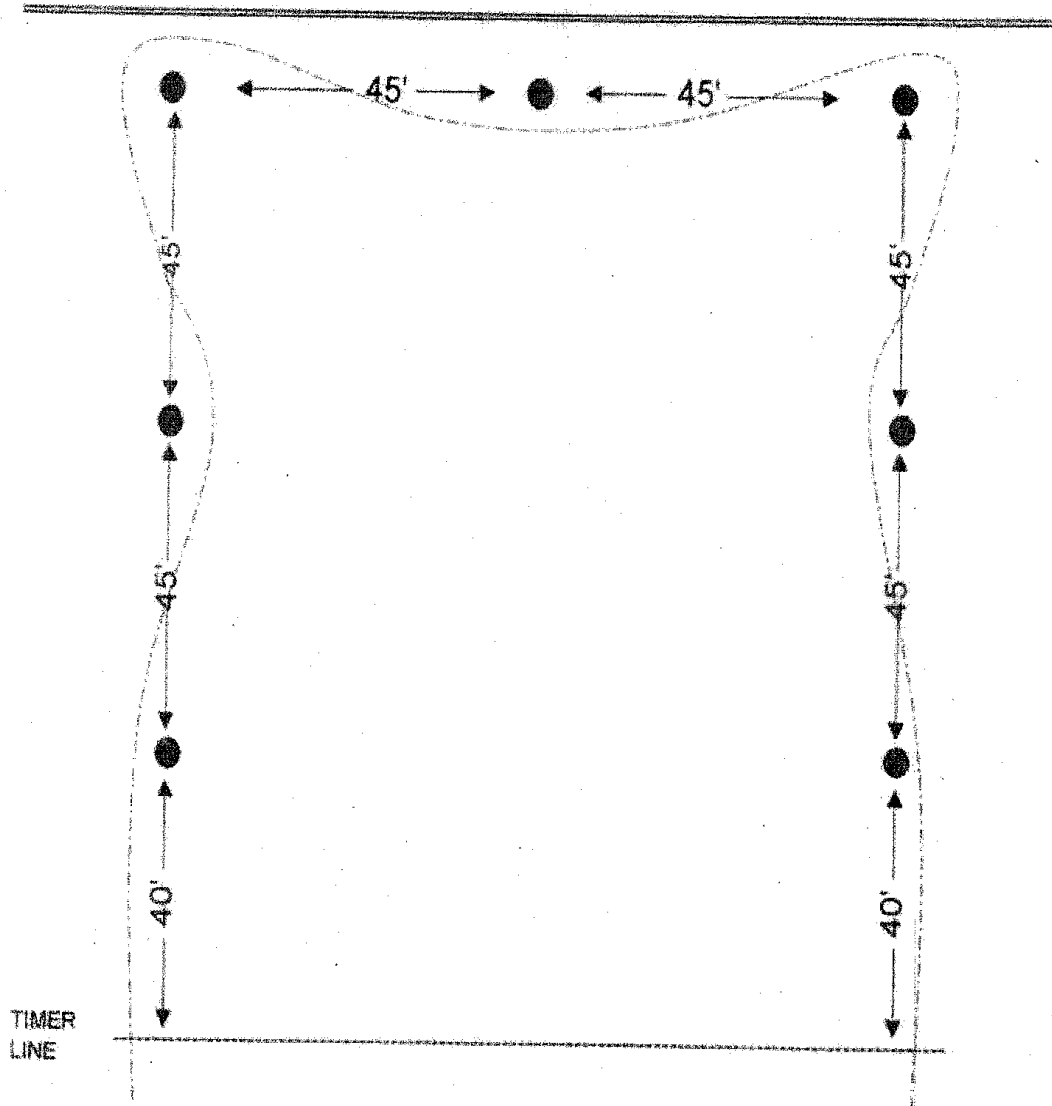

Left or right hand pattern may be used. If arena size warrants, adjust barrels so they are proportioned that the barrels closest to the fence are no closer than 15 feet from the fence.

Equipment: 7 large(55 gallon) barrels

Hourglass

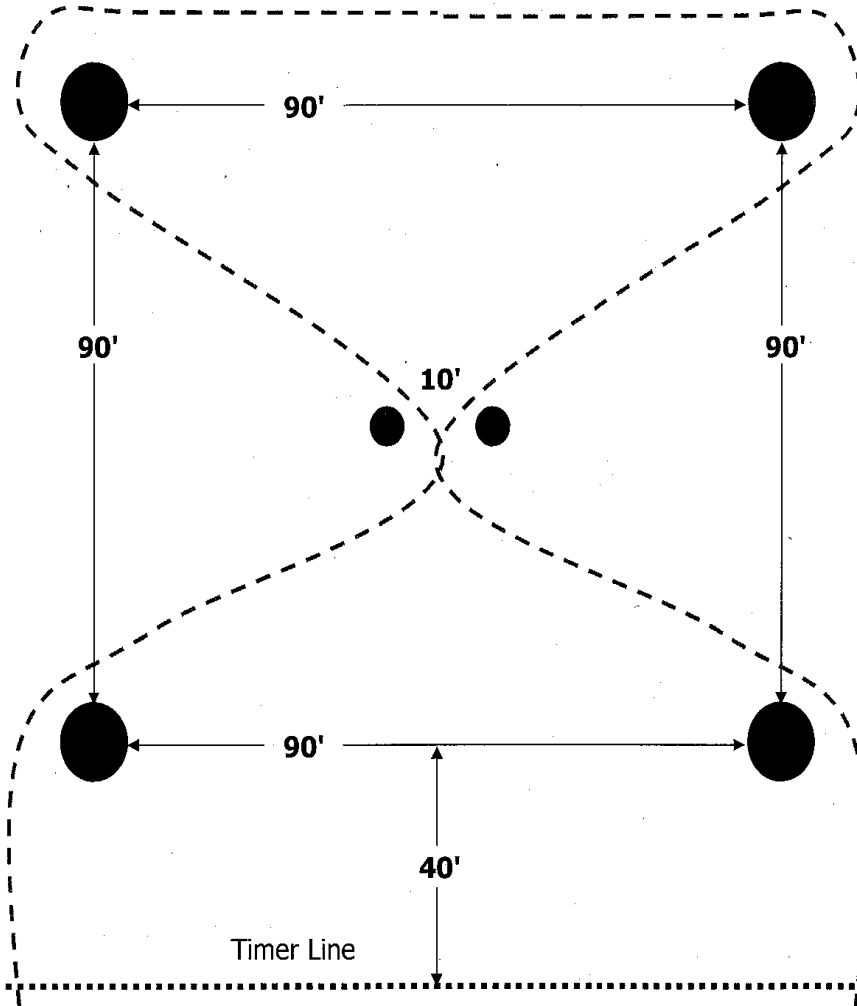

Left or right hand pattern may be used.
Props: 4 large barrels. 2 small barrels.

Open End Figure 8

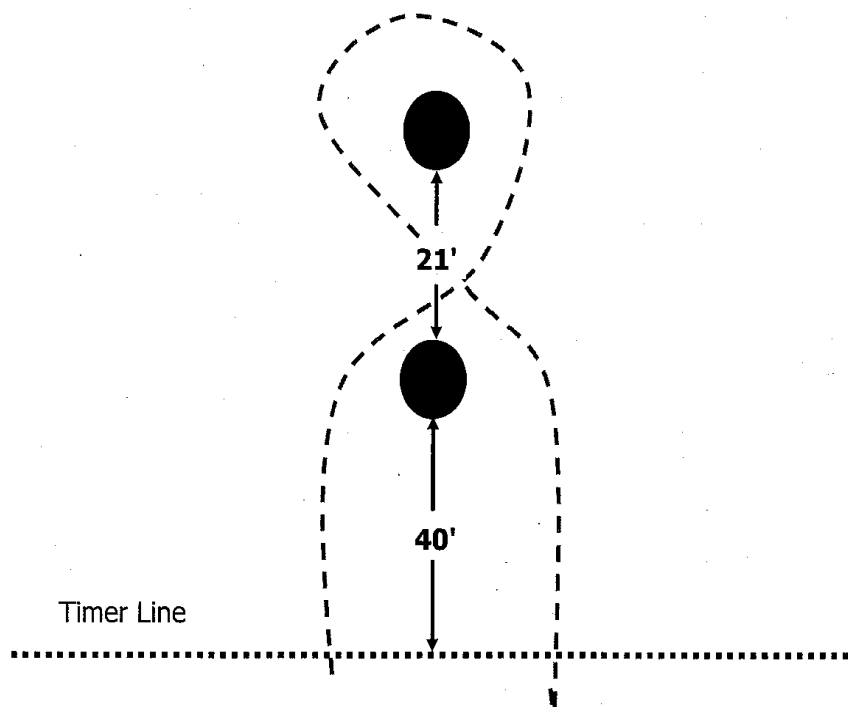

Left or right hand pattern may be used.
Props: 2 large barrels.

Phoenix Lights

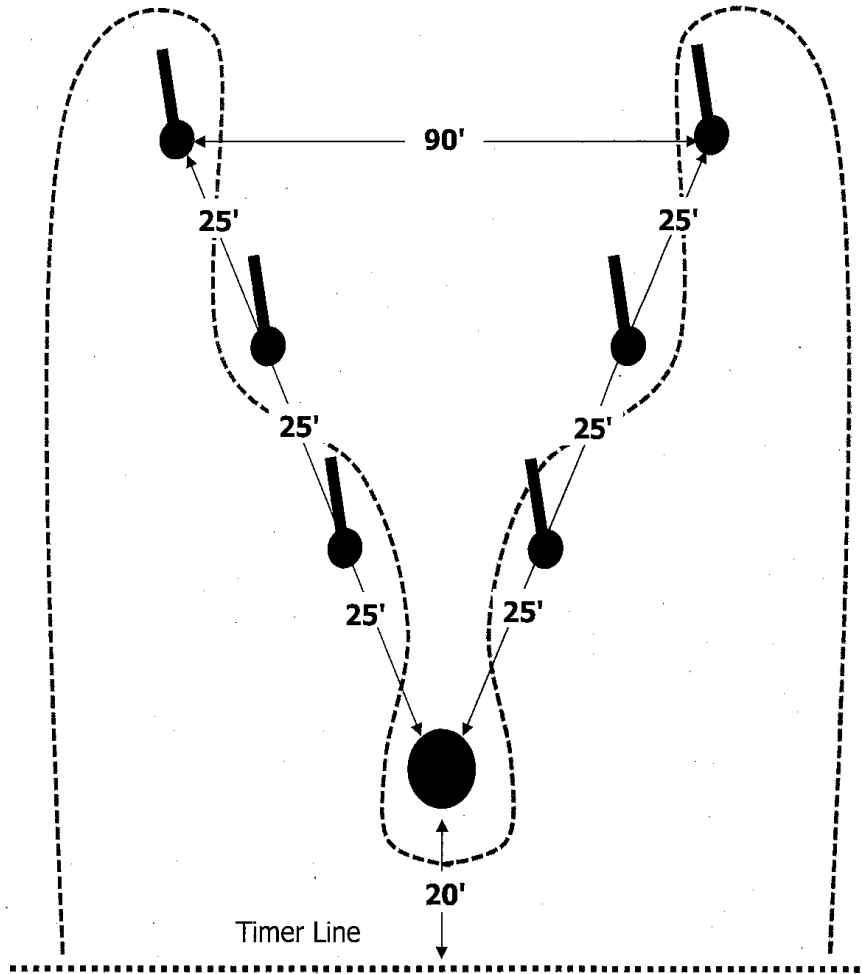

Left or Right pattern may be run.
Props: 1 large barrel. 6 poles.

Pole Keyhole

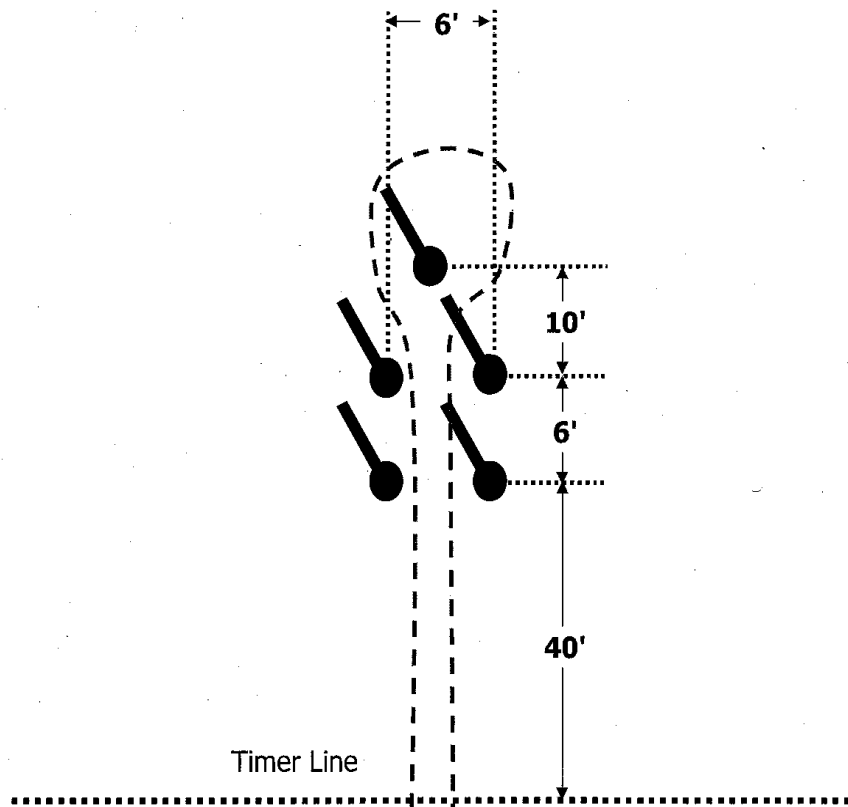

Left or right hand pattern may be used.
Props: 5 standard poles.

Reverse Pole Keyhole

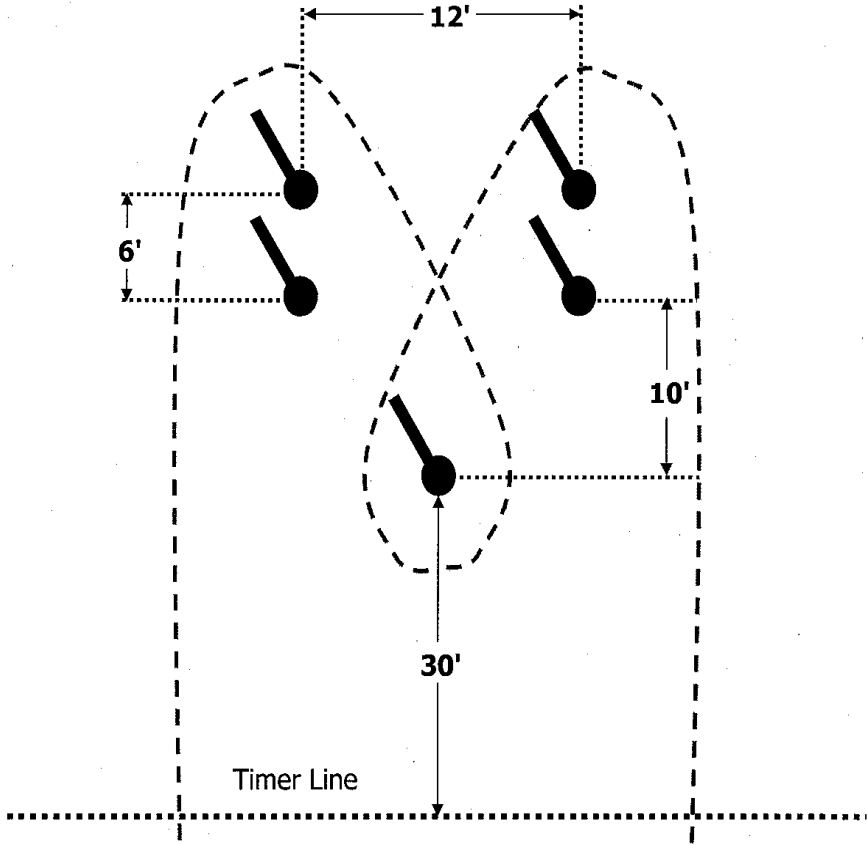

Left or right hand pattern may be used.
Props: 5 standard poles.

THREAD THE NEEDLE

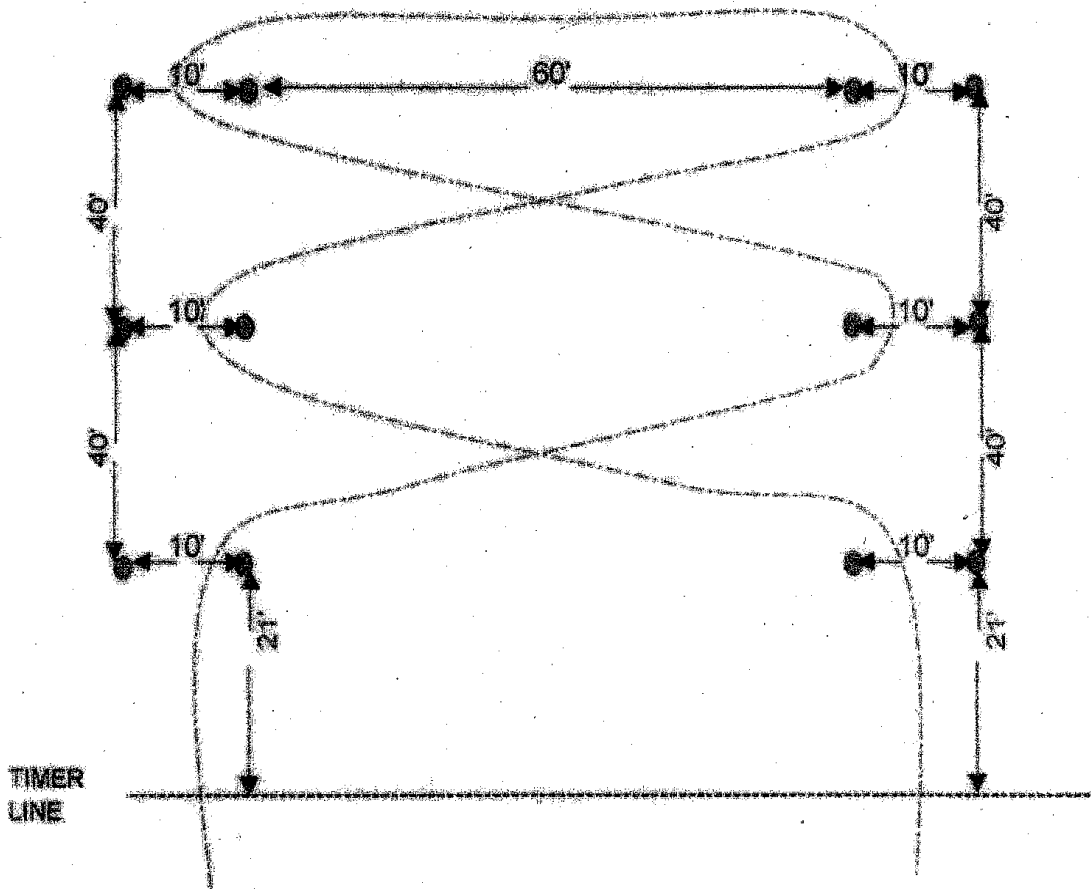

Left or right hand pattern may be used. Twelve cones are to be used.

Why

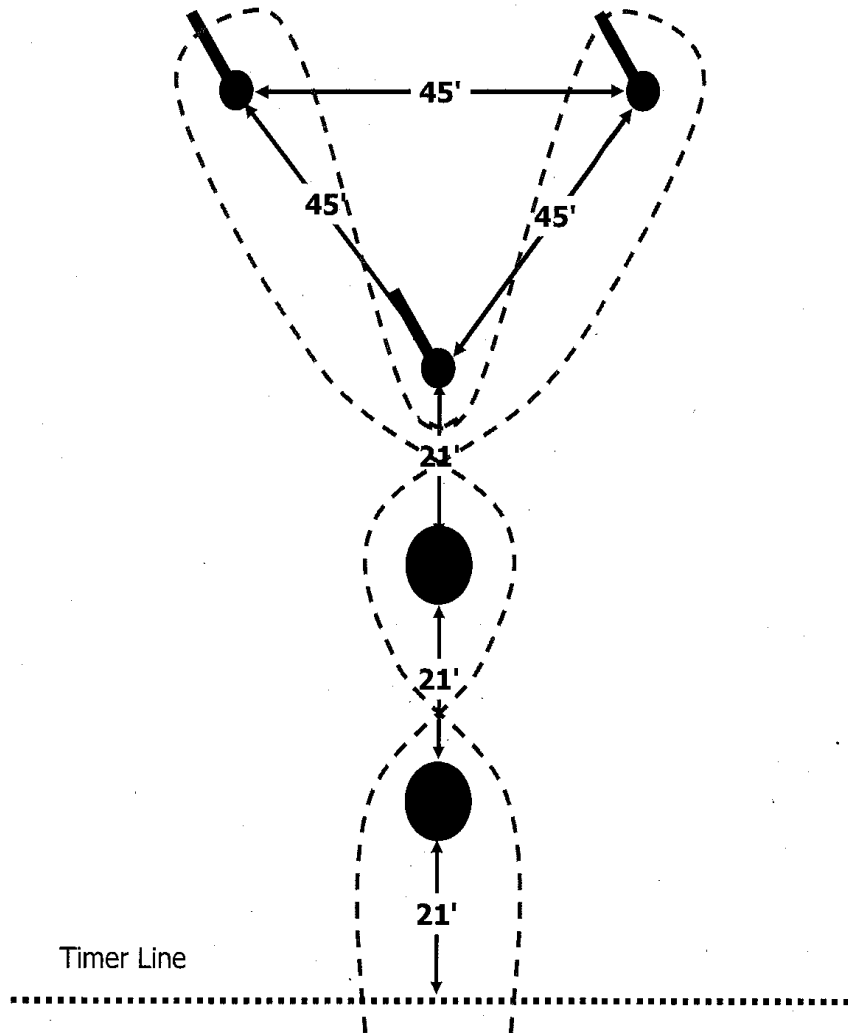

Left or right hand pattern may be used.
Props: 2 large barrels & 3 poles.

Timed Trail

1. Open to horses or ponies. Timed Trail shall work over and through obstacles. If gate is used, handle should be approximately 48 inches from ground. Rider may be asked to open gates, carry objects from one part of the arena to another, drag a log or other object for a short distance, either in a straight line or around a set pattern. (Rope is *not* to be tied to the saddle horn), ride through water, over logs or brush, ride down in to, and up out of, a ditch without lunging or jumping, cross over a bridge, back through obstacles, mount and dismount from either side, having the option of using a mounting block when mounting/dismounting, and perform any natural or simulated condition encountered along a trail. If a jump is used in Timed Trail, the height of the jump is limited to 18 inches. No less than 5 obstacles may be used.
2. All courses and obstacles are to be constructed with safety in mind to eliminate any possible accident.
3. Exhibitors must execute the course as posted, each obstacle will be assigned a point value and course will be timed from start to finish. Time penalties will be assessed for any refusal, balking, bolting or attempting to evade an obstacle by shying or backing more than two strides. Once the exhibitor has reached three refusals on an obstacle, they must move on to the next obstacle and will not receive points for the refused obstacle, but the time penalties will still be added to their overall time. An exhibitor who receives a penalty on any obstacle cannot place over another exhibitor who has not received any penalties regardless of his/her time.
4. Exhibitors will *not* be penalized for changing hands on the reins while working an obstacle.
5. The course must be posted by the show committee for the exhibitors to view at least 15 minutes before the start of the class.
6. No schooling is allowed on the course.

INDEX

A

Academy	22,25,31,50,51
Age of Equine	18,21,29,52
Age of Exhibitor	18,21,34,35,44,50,51,69,76
Attire	22-24
Awards	2,29,30

B

Bareback	55,76
Bats	22,24,25,27
Beginners	19,22,25,31,52
Bosal	25,26,52
Bits	25,26,27,52
Bridle Path Hack	47
By Laws	5-12

C

Chaps	22,23,24,49,77
Coggins	21
Combination English and Western	50
Combination Ride and Drive	61
Command Classes	49,71,72
Committees	10
Complaints	10,16
Constitution	5-12
Costume Class	50,53
Conduct	5-11
Crops	22,24,25,27,28,58,73

D

Discipline	13,17
Disciplined Rail	49
Dogs	19
Driving	18,19,22,25,28,30,53,57,58,59
Driving Division	60-72
Dues	7,8,10

E

English Division	25,47
Equipment	25
Equitation Division	54

F

Fitting and Showmanship	23,25,26,30,52,53
Five and Under	22,25,26,52

G

General Rules	18-21
Green Horse	19,22,25,26,52
Grievance	10,16,17,20
Gymkhana Division	11,76-102

H

Horse/Pony Definition	18
Horsemanship	9,18,54,55
Hunter Division	27,65
Hunter Hack	47
Hunter Pony	68
Hunter under Saddle	47
Hunt Seat Classes	48,55,56

I

In Hand Division	29,30,57,69,72
------------------	----------------

J

Jack Benny	18,30,50,76
Judges	11,19,20
Jumping	65
Junior Horse	21,26,27,52

L

Lameness	19,30
Lead line	23,27,30,51,52,76
Liberty Division	60
Lite Shod	24,27,68-72

M

Martingales	25,27
Membership	2,5,6,9,11,12,14
Miniature Horse Division	57
Mission Statement	5

O

Obedience	49
Officers	5-8,12
Order of Competition	75
One Hand	26,29
Open and Junior Jumping	65

P

Park Type	47
Pleasure Driving	18,60,61,64,71,72
Points	2,26,28,20,27,29,30
Pony Division	18,57,68,72-73
Pony 11.2 and Under In Hand Performance	73-75
Protests	16

R

Rabies, Proof of	21
Reining	26,40-44

S

Saddle Seat	19,22,24,25,47,48,51,53,55,56
Schooling	19,50,65,86
Showmanship	19,23,25,26,30-36,51,52,53,57
Soundness	19,30,36,66,67
Spurs	22,24,25,27
Stallions	18,25,30,52
Stock Horse	45,46

T

Tennessee Walking Horse	27,30,68-72
Tie Downs	26,27
Timers	19,75

Trail Division 49

U

Unruly Horse 20
Unsportsmanlike Conduct 16

V

Violations and Penalties 14,16
Voting 5,7,8

W

Walk/Trot/Jog/Alternate Gait 22,25,52,53
Western Division 36
Whips 25,27,28,58,59,60,73,74
Working Hunter 65,66

Y

Year End Awards 29,30

Modified rules for 2017 are bolded and underlined and can be found on pages 8,11,19,23,25,48,51,52,57,60 and 65.

Also for 2017 is an Attire Section (pages 22-24), an Equipment and Tack Section (pages 25-28) and Gymkhana Patterns (pages 88-103).

All changes for 2018 have (2018) next to the change (located on pages 2, 7, 8, 30, 52 & 57)